

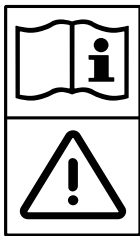

56384899, 56384900, 56384901

**INFORMATION
&
OPERATING
INSTRUCTIONS**

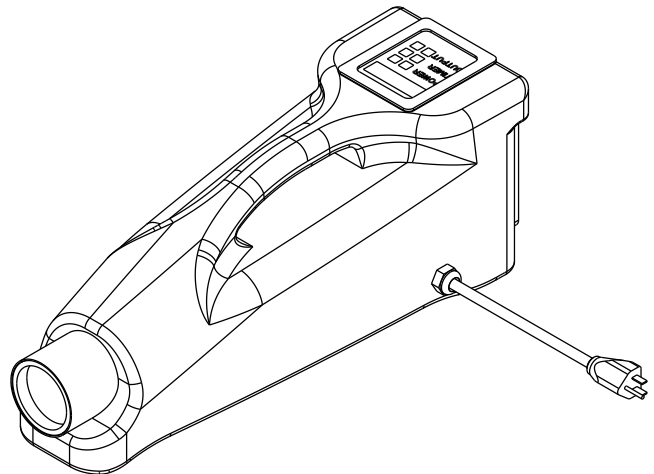

READ ALL INSTRUCTIONS BEFORE OPERATING

OZONE IS A POWERFUL OXIDIZER AND MUST BE USED WITH CARE

WARNING: USE IN UNINHABITED AREAS ONLY.

CONSULT MSDS SHEET BEFORE USE.

Ozone attacks organic matter. Limited exposure can cause irritation to eyes, throat, and nose, and it may cause nausea. **Do not re-inhabit a treated area until it has been well ventilated.** Prolonged exposure can also affect certain organic materials such as rubber, plastic, wire insulation. Do not get the machine wet.

INTRODUCTION

This manual will help you get the most from your equipment. Read it thoroughly before operating the machine.

This product is intended for commercial use only.

PARTS AND SERVICE

Repairs, when required, should be performed by your Authorized Service Center, who employs factory trained service personnel, and maintains an inventory of original replacement parts and accessories.

Call for repair parts or service. Please specify the Model and Serial Number when discussing your machine.

MODIFICATIONS

Modifications and additions to the cleaning machine which affect capacity and safe operation shall not be performed by the customer or user without prior written approval from the manufacturer. Unapproved modifications will void the machine warranty and make the customer liable for any resulting accidents.

NAMEPLATE

The Model and Serial Number of your machine are shown on the Nameplate. This information is needed when ordering repair parts for the machine. Use the space below to note the Model and Serial Number of your machine for future reference.

Model _____

Serial Number _____

UNPACKING THE MACHINE

When the machine is delivered, carefully inspect the shipping carton and the machine for damage. If damage is evident, save the shipping carton so that it can be inspected.

WARNING!

The Products sold with this Manual contain or may contain chemicals that are known to certain governments (such as the State of California, as identified in its Proposition 65 Regulatory Warning Law) to cause cancer, birth defects or other reproductive harm. In certain locations (including the State of California) purchasers of these Products that place them in service at an employment job site or a publicly accessible space are required by regulation to make certain notices, warnings or disclosures regarding the chemicals that are or may be contained in the Products at or about such work sites. It is the purchaser's responsibility to know the content of, and to comply with, any laws and regulations relating to the use of these Products in such environments. The Manufacturer disclaims any responsibility to advise purchasers of any specific requirements that may be applicable to the use of the Products in such environments.

IMPORTANT SAFETY INSTRUCTIONS

This machine is only suitable for commercial use, for example in hotels, schools, hospitals, factories, shops and offices other than normal residential housekeeping purposes.

When using any electrical appliance, basic precautions should always be followed, including the following:

NOTE: Read all instructions before using this machine.

WARNING!

To reduce the risk of fire, electric shock, or injury:

- USE IN UNINHABITED AREAS ONLY.
- To avoid electric shock, do not expose to rain or snow. Store and use indoors.
- Use only as described in this manual. Use only the manufacturer's recommended attachments.
- Do not use with damaged cord or plug. If the machine is not working as it should, has been dropped, damaged, left outdoors or dropped into water, return it to a service center.
- Do not pull by the cord, use the cord as a handle, close a door on the cord, or pull the cord around sharp edges or corners. Keep the cord away from heated surfaces. To unplug, grasp the plug, not the cord.
- Do not handle the plug, the cord or the machine with wet hands.
- Extension cords must be 12/3 and no longer than 50 feet. Replace the cord or unplug immediately if the ground prong becomes damaged.
- Do not put any object into openings. Do not use with any opening blocked; keep free of dust, lint, hair, and anything that may reduce air flow.
- Connect to a properly grounded outlet only.

SAVE THESE INSTRUCTIONS

120VAC GROUNDING INSTRUCTIONS

This appliance must be grounded. If it should electrically malfunction, grounding provides a path of least resistance for electric current to reduce the risk of electric shock. This appliance is equipped with a cord having an equipment-grounding conductor and grounding plug. The plug must be plugged into an appropriate outlet that is properly installed and grounded in accordance with all local codes and ordinances.

DANGER!

Improper connection of the equipment-grounding conductor can result in a risk of electric shock. Check with a qualified electrician or service person if you are in doubt as to whether the outlet is properly grounded. Do not modify the plug provided with the appliance. If it will not fit the outlet, have a proper outlet installed by a qualified electrician.

This appliance is for use on a nominal 120-volt circuit, and has a grounding plug that looks like the plug illustrated in Figure 1 below. A temporary adapter illustrated in Figures 2 and 3 may be used to connect this plug to a 2-pole receptacle as shown in Figure 2 if a properly grounded outlet is not available. The temporary adapter should be used only until a properly grounded outlet (Figure 1) can be installed by a qualified electrician. The green-colored rigid ear, tab, or the like extending from the adapter must be connected to a permanent ground such as a properly grounded outlet box cover. Whenever the adapter is used, it must be held in place by a metal screw. Grounding adapters are not approved for use in Canada. Replace the plug if the grounding pin is damaged or broken.

The Green (or Green/Yellow) wire in the cord is the grounding wire. When replacing a plug, this wire must be attached to the grounding pin only. Extension cords connected to this machine should be 12 gauge, three-wire cords with three-prong plugs and outlets. DO NOT use extension cords more than 50 feet (15 m) long.

PLEASE NOTE: FOR NORTH AMERICA ONLY

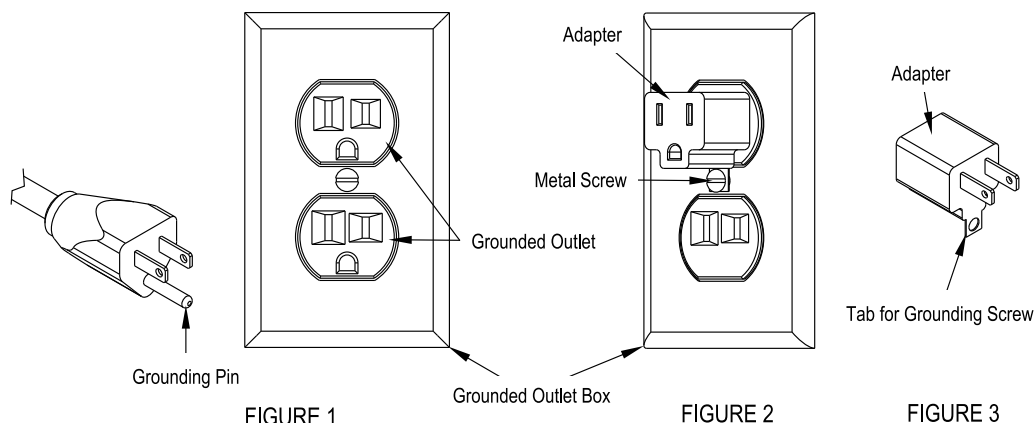

READ ALL INSTRUCTIONS BEFORE OPERATING**OZONE IS A POWERFUL OXIDIZER AND MUST BE USED WITH CARE****⚠ WARNING!**

Use in uninhabited areas only. CONSULT MSDS SHEET BEFORE USE.

Ozone attacks organic matter. Limited exposure can cause irritation to eyes, throat, and nose, and it may cause nausea. Do not re-inhabit a treated area until it has been well ventilated. Prolonged exposure can also affect certain organic materials such as rubber, plastic, wire insulation. Do not get the machine wet.

All cleaning and maintenance work should be completed before using the Ozone machine.

Ozone treatment should be the final step in room maintenance.

NOTE: the air flowing into the machine must be clean and dry.

NOTE: if the air intake filter is dirty or missing warranty is voided.

OPERATION:**NOTE: OZONE IS A TOXIC GAS. FOLLOW ALL SAFETY PRECAUTIONS.**

1. Make certain all people, pets, and plants are out of area. Close all windows and doors.
2. Make sure the filter in front of the cooling fan is installed and is clean.
3. Place the Oasis Plus unit on a shelf or tabletop as high as possible in the area to be treated.
4. Plug the power cord into a grounded, 3-prong outlet.
5. Set the timer to the desired length of time. Momentarily pressing the UP timer button for one second will increase the time setting by one minute at a time. Hold the button for 1 -3 seconds to change the time value by two minutes per second. Hold the button for longer than 3 seconds and the time setting will change in 20 minutes increments. The maximum time setting is 29:59 hours. After reaching the maximum time, the timer will wrap back to 00:00 and then continue increasing. When the time is being decreased and reaches 00:00, it will wrap to 29:59 and continue decreasing.
6. Select the desired power level: 25%; 50%; 75% 100%. The Oasis Plus always defaults to 100% when you plug it in. When the output level is set to 100%, the machine makes ozone continuously until the timer runs out or the OFF button is pressed. At other power level settings, the machine will produce ozone for the fraction of a minute the level is set at. For example, if the output level is set to 75%, the machine will produce ozone for 75% (45 seconds) of each minute. At 50%, ozone is generated for 30 seconds of each minute, and at 25%, the ozone generation lasts for 15 seconds of each minute. On any setting other than 100%, the ozone generator will be cycling the ozone ON and OFF.
7. Turn the unit on by pressing the ON button. Leave the area immediately.
8. When treatment is complete, unplug the ozone machine and ventilate the area completely until all smell of ozone is gone. Do NOT allow people, pets, or plants back into the area until all smell of ozone has dissipated.

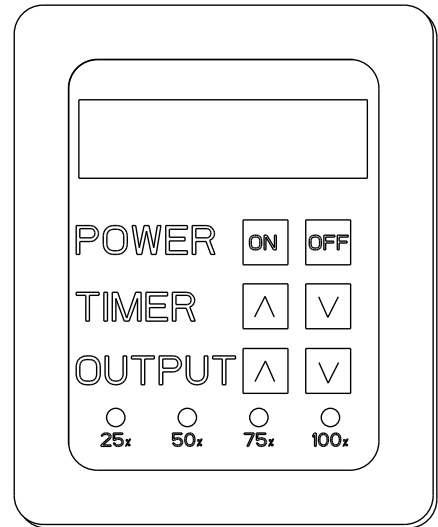

TIME GUIDELINES:

This Oasis Plus unit will control biological contamination and odor in areas up to 40,000 FT³.
Use the following times as a guideline.

Hotel/Motel Room:	20 -- 60 Minutes
Automobiles:	20 -- 30 Minutes
Fire & Flood Restoration:	12 -- 72 Hours.

For Automobiles:**Refer to Figure 1 and Figure 2 below**

1. Install the hose onto the electrode chamber. Secure the hose with the hose clamp.
2. Set the Ozone Plus on top of the car or on a cart or table next to the car.
3. Install the foam block into a partially closed car window, and insert the hose through the hole in the foam.
4. Set the time and the output level.
5. Turn the ozone machine ON.

NOTE: When treatment is complete, ventilate the car completely. Repeat treatment if necessary.

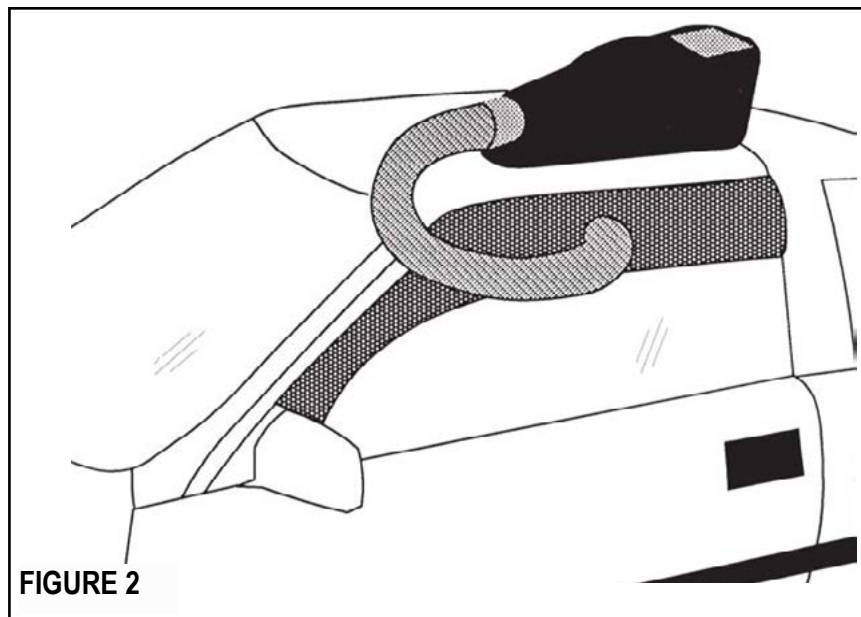
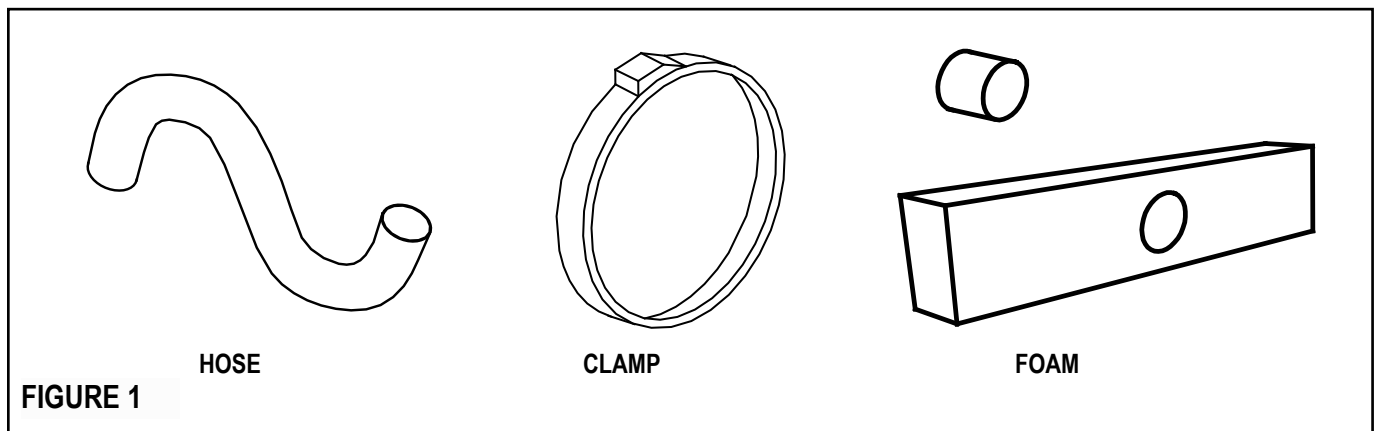

NOTE: Ozone destroys odor causing molecules, thus eliminating the source of the odor. The length of time this process takes will vary depending on the amount of contaminants the ozone has to work on, the amount of area being treated, temperature and humidity, the amount and type of furniture in the area, etc.

NOTE: the process can produce a haze in the treatment area.

TROUBLESHOOTING**⚠ CAUTION!**

ALWAYS UNPLUG THE MACHINE BEFORE YOU DO ANY INTERNAL TROUBLESHOOTING

IF THIS OCCURS	CHECK THIS
NO POWER	Look at the power cord, to make sure it is plugged in. Check the outlet, to make sure it has power in it. Look at the circuit breaker on the bottom of the machine, to make sure it has not tripped. Check the internal safety switch to make sure it is 'activated' when the bottom cover is on.
TIMER DOES NOT WORK	The digital display has segments missing from some numbers. The timer ^ or v buttons do not change the time display. The time display does not change as time passes.
THE % of OZONE DOES NOT WORK	The % button does not work. The amount of ozone output does not change. The % button does work, but one (or more) of the red LEDs is not lighting.

NOTE: if the air intake filter is dirty or missing warranty is voided.

SPECIFICATIONS AND FEATURES:

Output Volume	Variable
Maximum Output:	2.2 gm/HR; 6.6 ppm
Timer:	Digital, 00:00 to 29:59 hours
Production Method:	Patented, high-density and stainless steel electrodes
Air Flow:	100 CFM
Dimensions:	8"H X 8"W X 22"L
Weight:	12-1/2 lbs
Warranty:	3 year; lifetime on electrodes *

* A dirty or missing filter at the air intake voids the warranty

- Rugged construction means reliability
- No maintenance of plates or UV tubes
- Over-load protection

OASIS PLUS

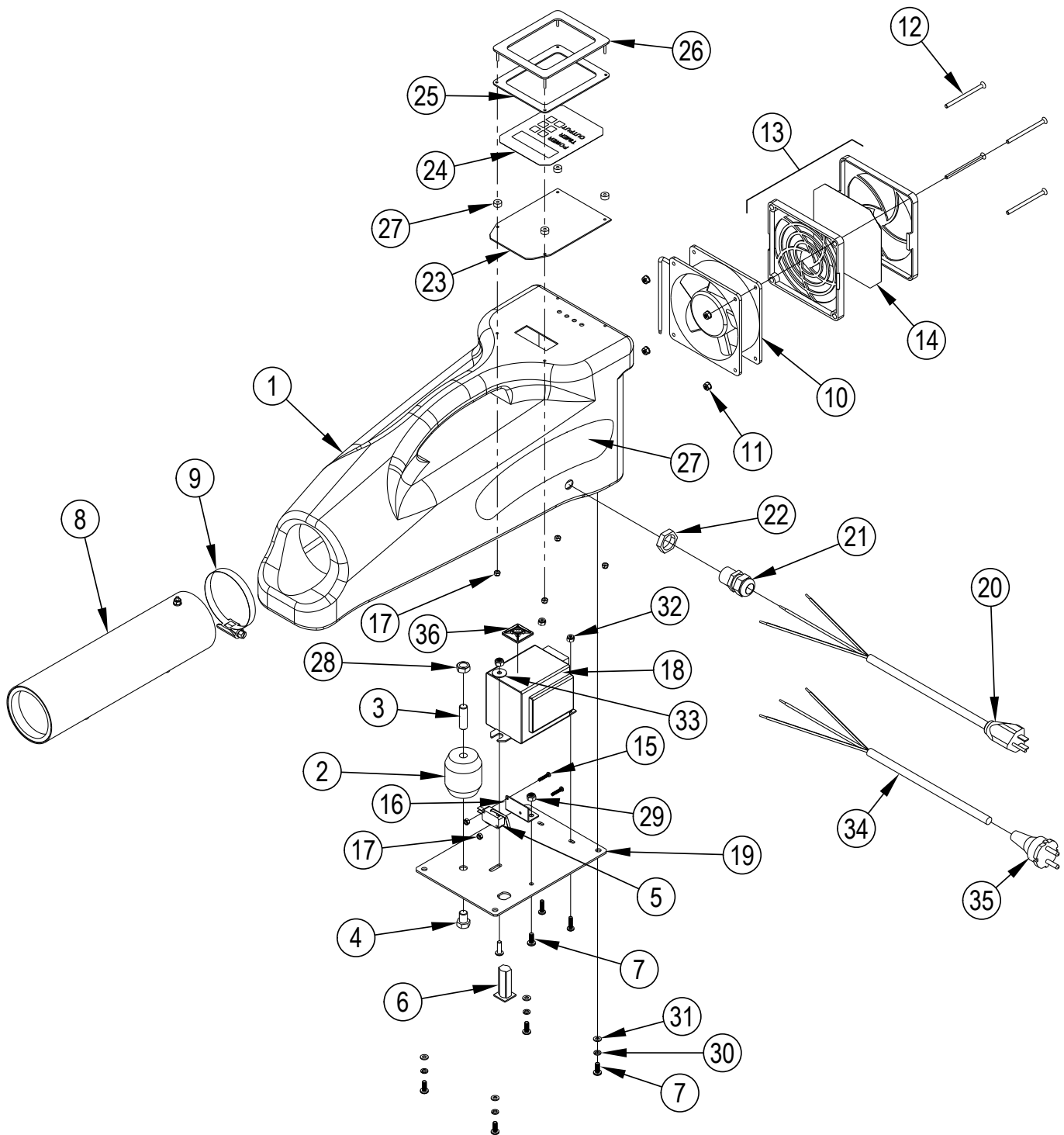

OASIS PLUS

Item	Ref. No.	Qty	Description
1	FP575	1	Body Black Plastic For Oasis-P
2	OZ-10	1	Terminal Block High Voltage
3	327	1	Stud 3/8 X 1-1/4 S/S
4	326	1	Bolt 3/8 X 1/2 Hex S/S Full
5	OZ-8	1	Switch Safety For Ozone
6	OZ-5	1	Circuit Breaker .5a For Eon-
7	364	5	Bolt 10-32 X 1/2 Ph Phl S/S M
8	FP242	1	Ozone Electrode Chamber
[]	FP241	6	Ozone Electrode 1 Ea. Lon-g
9	198USP	1	Hose Clamp 48 3-1/2dia 9
10	2014	1	Fan 4 100cfm 120 Volt Equip (56384899, 56384900)
10	2018	1	Fan 4 100cfm 230 Volt Equip (56384901)
11	324	4	Nut Keps 8-32 S/S
12	323	4	Screw 8/32 X 2 1/2s/S Flat
13	2015A	1	Fan Cover & Filter Assy (56384899, 56384900)
13	2015C	1	Fan Cover & Filter Assy (56384901)
14	2015B	1	Filter S/S Screen 100 Mesh
15	328	2	Screw 4-40 X 5/8 M.S. S/S Pa
16	OZ-22	1	Bracket For Ozone Safety Switch
17	18	6	Nut Nylon Lock 4-40 Stainless
18	SUBOZ-4PTI-1	1	Transformer 120v. High Voltage (56384899, 56384900)
18	OZ-4PTI-240	1	Transformer 240v High Voltage (56384901) TSB-FC-2014-013
19	OZ-18AC	1	Mounting Plate Bottom Panel Oz
20	OZ-11	1	Power Cord 16/3 Sjt/w 8 Bl
21	230USP	1	Retainer Power Cord Water Tight
22	230A	1	Lock Nut Nylon For Cord Retainer
23	56381735	1	Pcb Assy-Ozone Gen 120v (56384899, 56384900)
23	56381520	1	Pcb Assy-Ozone Gen 240v (56384901)
24	OZ-20A	1	Membrane For Ozone Blank
25	OZ-16A	1	Gasket Ozone Bezel1/16 Epdm
26	OZ-16	1	Bezel For Control Panel Display
27	56384925	2	Decal-Oasis Plus
29	17	2	Nut Nylon Lock 10/32 Stainless
30	23B	4	Washer Lock 10 Split S/S
31	26	4	Washer Backup For 3/16 Rive
32	325	2	Nut Nylon Lock 8-32 Stainless
33	1326A	1	Washer Flat S.S 10 X 11/1
34	2019	1	Power Cord European Color Code (56384901)
35	298USP	1	Electrical Plug European Style (56384901)
36	1312	3	Mounting Pad
[]	35	7	Tie 4 Black Weather Resis
[]	56380998	1	Decal-Oasis Ozone Warning
[]	317	1	Clamp Hose 3 Plastic (56384900)
[]	430C	1	Hose 3 X 4 Polyethylene Mold (56384900)
[]	OZ-FOAM	1	Foam Block 6 X 30 X 4 W/ 3 (56384900)

[] = Not Shown

WIRING DIAGRAM

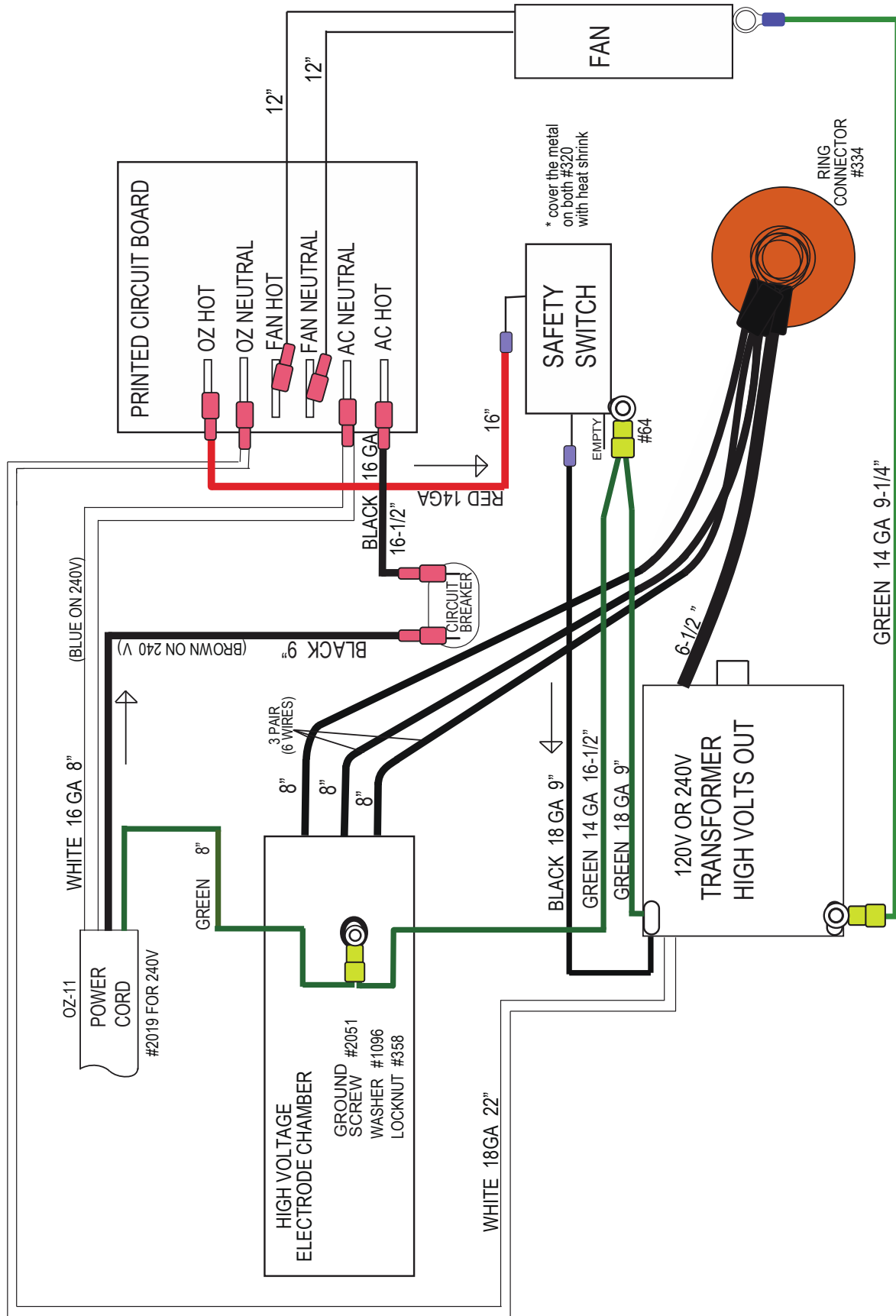



800.426.1301 / 425.775.7272
11015 - 47th Avenue West / Mukilteo, WA 98275

www.hydramaster.com