

HYDRAMASTER

Corporation

11015 47th Avenue W, Mukilteo, WA 98275

BOXXER **427**

Machine Serial Number _____

Copyright© 2012

HYDRAMASTER© Corporation
Mukilteo, Washington

MAN-45068 Rev. 0 (182-068)

No part of this manual may be reproduced or used in any form or by any means (i.e. graphic, electronic, photocopying or electronic retrieval systems) without the express written permission of the **HYDRAMASTER**© Corporation. All rights reserved.

Revised March 23, 2012

Table of Contents

Table of Contents

List of Figures

Quick Reference

GENERAL INFORMATION	Section 1
Telephone Numbers	1-2
Precautions	1-3
System Operation	1-7
Machine Specifications	1-8
Spare Parts Recommendation	1-10
Spare Parts List	1-10
Responsibilities	1-12
Vehicle Preparation	1-14
High Altitude Operation Preparation	1-18
Local Water Precautions	1-19
Wastewater Disposal Advisory	1-20
Hard Water Map	1-23
Machine Assemblies and Parts Lists	1-25
Boxxer Hose Assemblies	1-85
CLEANING AND CHEMICALS	Section 2
pH Chart	2-3

OPERATING INSTRUCTIONS Section 3

- Start Up 3-1
- Carpet or Hard Surface Cleaning 3-1
- Upholstery Cleaning 3-2
- Flood Extraction 3-3
- Shut Down 3-4
- Exhaust Diverter 3-5

FREEZE GUARD Section 4

- Freeze Protection of Pump-In System 4-3

WATER AND CHEMICAL SYSTEM Section 5

- Chemical System Maintenance 5-2
- Chemical Pump 5-3
- Solution Flow Diagram 5-5
- Chemical Flow Diagram 5-6
- Exhaust, Vacuum, Coolant and APO Flow Diagram 5-7
- Chemical Tank Troubleshooting 5-8

HIGH PRESSURE PUMP Section 6

- Pump Maintenance 6-1
- Service 6-2
- HydraPump IV Drawing and Parts List 6-6
- Pump Troubleshooting 6-8

CLEANING WAND PARTS Section 7

- Cleaning Wand Assembly Drawing 7-1

Boxxer 427

VACUUM SYSTEM	Section 8
Blower Troubleshooting/Miscellaneous Troubleshooting	8-3
MD Blower Instruction Booklet	
ENGINE TROUBLESHOOTING	Section 9
ELECTRICAL SYSTEM	Section 10
Wiring Schematic	10-2
Wiring Diagrams	10-3,-4,-5
Electrical Troubleshooting	10-6
MACHINE MAINTENANCE	Section 11
Daily, Weekly	11-1
Monthly, Quarterly, 500 Hours	11-2
De-scaling	11-3
Machine Maintenance	11-4
Maintenance Logs	
HOW TO ORDER PARTS	Section 12
WARRANTY INFORMATION	Section 13
Golden Guarantee®	
ACCESSORIES	Section 14
PRODUCT UPDATES	Section 15

List of Figures

Fig. 1-1	Plywood Installation	1-14
Fig. 1-2	Astroturf and Roof Vent Installation	1-14
Fig. 1-3	Recommended Placement	1-15
Fig. 1-4	Installation Using Tie-down Cleats	1-16
Fig. 1-5	Hard Water Map	1-23
Machine Assemblies and Parts Lists		1-25
Fig. 1-6	Machine Assembly - Front View - Left Side	1-25
Fig. 1-7	Machine Assembly - Front View - Right Side	1-26
Fig. 1-8	Machine Assembly - Rear View - Right Side	1-27
Fig. 1-9	Frame Assembly - Front View - Left Side	1-29
Fig. 1-10	Frame Assembly - Front View - Right Side	1-30
Fig. 1-11	Frame Assembly - Rear View - Left Side	1-31
Fig. 1-12	Engine Assembly - Rear View	1-33
Fig. 1-13	Engine Assembly - Front View	1-34
Fig. 1-14	Exhaust Assembly	1-36
Fig. 1-15	Diverter Valve Actuator Assembly	1-38
Fig. 1-16	Blower Assembly	1-39
Fig. 1-17	Pump Assembly	1-41
Fig. 1-18	Chemical Pump Assembly	1-43
Fig. 1-19	Pump Mounting Bracket Assembly	1-44
Fig. 1-20	Water Box Assembly	1-46
Fig. 1-21	Dash Upper Assembly - Front View	1-48
Fig. 1-22	Dash Upper Assembly - Rear View	1-49

Boxxer 427

Fig. 1-23 Dash Guage Panel Assembly	1-51
Fig. 1-24 Lower Dash Assembly - Front View	1-53
Fig. 1-25 Lower Dash Assembly - Rear View	1-54
Fig. 1-26 By-Pass Valve Assembly	1-56
Fig. 1-27 HI-PSI Manifold Assembly	1-58
Fig. 1-28 Electrical Control Panel Assembly	1-60
Fig. 1-29 Coolant Heat Exchanger Assembly	1-61
Fig. 1-30 Blower Heat Exchanger Assembly	1-64
Fig. 1-31 Top Cover Assembly	1-66
Fig. 1-32 Machine Right Side Cover Assembly	1-67
Fig. 1-33 Machine Left Side Cover Assembly	1-68
Fig. 1-34 70 Gallon Universal Recovery Tank Assembly	1-69
Fig. 1-35 70 Gallon Universal Recovery Tank Cover Assembly	1-72
Fig. 1-36 100 Gallon Universal Recovery Tank Assembly	1-73
Fig. 1-37 100 Gallon Universal Recovery Tank Cover Assembly ..	1-76
Fig. 1-38 Vacuum Relief Valve Assembly (Collector Box)	1-77
Fig. 1-39 Dura-Flow APO Pump Assembly	1-79
Fig. 1-40 Chemical Jug Tray Assembly	1-81
Fig. 1-41 Diffuser Filter Assembly	1-83
Fig. 1-42 Float Switch w/ Polypropylene Barrel Assembly	1-84
Fig. 2-2 Cleaning Stroke Procedure	2-3
Fig. 2-1 pH Chart	2-3
Fig. 2-2 Cleaning Stroke Procedure	2-3

Fig. 4-1	Recirculation Fitting	4-1
Fig. 5-1	Chemical Pump Assembly	5-3
Fig. 5-2	Solution Flow Diagram	5-5
Fig. 5-3	Chemical Flow Diagram	5-6
Fig. 5-4	Exhaust, Vacuum, Coolant, and APO Flow Diagram	5-7
Fig. 6-1	Servicing the Valves	6-3
Fig. 6-2	HydraPump II Assembly	6-6
Fig. 7-1	Two-Jet Cleaning Wand Assembly	7-1
Fig. 10-1	Wiring Schematic	10-2
Fig. 10-2	Wiring Diagram Sht 1.	10-3
Fig. 10-3	Wiring Diagram Sht 2	10-4
Fig. 10-4	Wiring Diagram Sht 3	10-5
Fig. 11-1	Recirculation Fitting	11-3

Quick Reference

Fuel Pump Assembly
B4627 Rev—

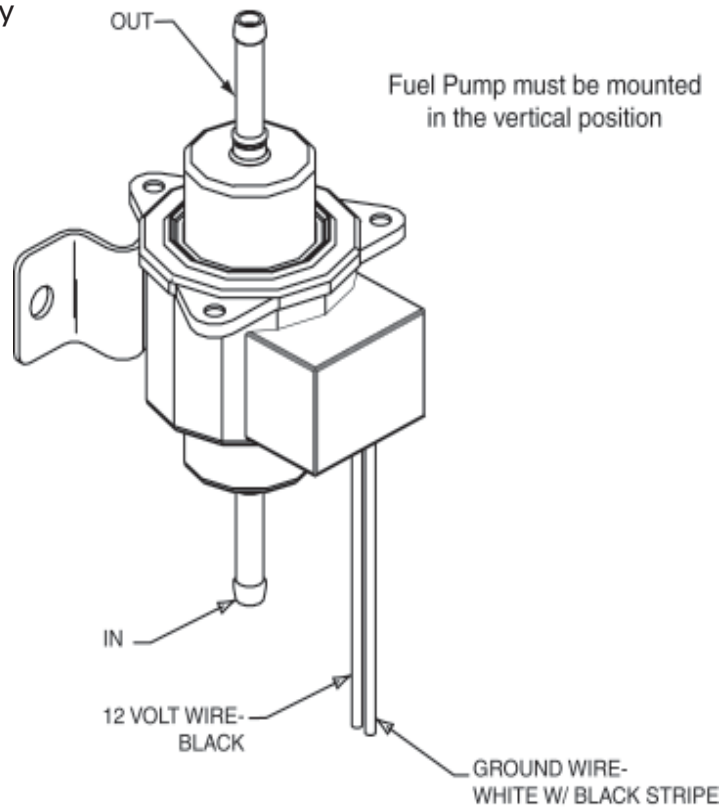

General Information

Section 1-1

This manual contains installation and operation instructions as well as information required for proper maintenance, adjustment and repair of this unit. Since the first and most important part of repair work is the correct diagnosis of the problem, component manual troubleshooting charts have been included for your convenience.

Unlike a garden tractor, lawn mower or cement mixer, all having one or two functions to perform, the truckmounted carpet cleaning plant has many functions to perform simultaneously.

- The engine has to run at a consistent RPM.
- The vacuum has to pull air and dirty water back from cleaning site.
- The water pump provides stable pressure at proper water flow for cleaning.
- The chemical has to be injected into the water stream at the right concentration.
- The heating system must maintain proper heat.
- The vacuum tank must store dirty water until drained.

As you can see, it is not just a turnkey operation with one thing to worry about, **Does it start?**

 **WARNING**

The manufacturer uses this symbol throughout the manual to warn of possible injury or death.

 **CAUTION**

This symbol is used to warn of possible equipment damage.

<u>Hours</u>	<u>Telephone Numbers</u>
Monday - Friday	(425) 775-7276 Parts
8:00 am to 5:00 pm	(425) 775-7275 Service
PACIFIC STANDARD TIME	(800) 426-4225 Parts / Service FAX

Precautions

Although this unit has been factory adjusted, it may require additional adjustments to achieve optimum performance, for instance altitude may require carburetor adjustment and ambient temperatures may require heat control adjustment. When required, consult an authorized representative.

 **CAUTION**

THROUGH-FLOOR DRILLING: Be cautious when drilling holes through the van floor. Many vans have critical components mounted directly below the van floor that could be damaged by a misplaced drill bit. (See Product Support Bulletins 92102, 94062 and 94063 at the end of the manual.)

 **CAUTION**

ENGINE COOLING: Units employing internal combustion engines must not be enclosed within a van with doors and windows closed. Excessive temperatures within the engine will result in premature engine failure and a compromise of applicable warranty.

 **CAUTION**

LEVEL OPERATION: During operation, van or trailer must be parked on level ground not to exceed + or - 10 degrees. Failure to insure proper leveling may prevent proper internal lubrication of engine, vacuum and/or high pressure components.

 **WARNING**

MOVING PARTS: Never touch any part of the machine that is in motion. Severe bodily injury may result.

 **WARNING**

The machine cannot be run in the IDLE position for cleaning upholstery, carpet or floor extraction. This will void the warranty.

 **CAUTION**

ACID RINSE AGENTS: The increased demand for “clear water” rinsing results in the need for special care when using these acid based chemicals in your equipment. The negative side of these products is the corrosive effects the acid can have on metals, including swivels, pumps, heat exchangers, etc.

HydraMaster’s *ClearWater Rinse* has been formulated to protect vital components. HydraMaster will not warranty parts that have been damaged from using unprotected acid products that have obviously caused failures.

 **CAUTION**

HARD WATER PROTECTION: Failure to take appropriate measures to prevent scale build up can result in **system failure** and **loss of warranty** on affected parts. Test the water in your immediate and surrounding areas with hard water test strips. Assume all water obtained from wells is hard. If you are operating in a “Hard Water Area” (3.5 grains or more per gallon), use a water softening system.

 **CAUTION**

FREEZE PROTECTION: There is often little warning before a cold spell. Therefore, not protecting this equipment from freezing will result in costly downtime. Placing an electric heater in the truck or parking the truck indoors will help to insure against freezing, but should not be the primary method of freeze protection.

 **CAUTION**

EXHAUST SYSTEM: Do not allow flammable material (i.e. oil, fuel, plastic or wood products) to come in contact with the exhaust system.

 **WARNING**

HOT SURFACES: During the operation of this equipment, many surfaces on the machine will become very hot. When near the van for any reason care must be taken not to touch any hot surface, such as heater, engine, exhaust, etc.

 **WARNING**

HEARING PROTECTION: The Occupational Safety and Health Administration (OSHA) recommends the use of hearing protection when a technician is exposed to an *average* of 85 decibels (this is an average of exposure over an 8 hour period). This equipment can produce 85 decibels to a distance of 10 feet. Please check with your local state agencies to see if OSHA standards apply to your application.

 **WARNING**

NO SMOKING: It is unsafe to smoke in or around the vehicle.

 **WARNING**

CARBON MONOXIDE: This unit generates toxic fumes. Position the vehicle so that the fumes will be directed *away* from the job site. *Do not park where exhaust fumes can enter a building through open doors, windows, air conditioning units or kitchen fans.*

 **WARNING**

TOXIC FUMES: Do not occupy the vehicle when the cleaning equipment is operating. Toxic fumes may accumulate inside a stationary vehicle.

 **WARNING**

ENGINE EXHAUST: The engine exhaust from this product contains chemicals known to the State of California to cause cancer, birth defects or other reproductive harm.

 **WARNING**

PORTABLE GAS TANK: Never operate this machine with a portable gas can inside the truck. Doing so increases the risk of a fire or explosion.

 **WARNING**

PORTABLE PROPANE TANK: Do not use a portable tank inside of the truck or van. It is dangerous and illegal in most states.

 **WARNING**

TRANSPORTATION OF FUEL CONTAINERS: Transportation in a vehicle of any vented fuel container that presently has or has ever contained a flammable liquid is strictly forbidden by HydraMaster Corporation and by federal and state regulation.

 **CAUTION**

The use of some chemicals through your mobile carpet cleaning plant can seriously damage the internal plumbing, high-pressure pump, chemical pump and heat exchangers. These harmful chemicals include concentrated acid (see the pH chart at the end of this section), solvents (including d-Limonene), and some paint, oil and grease removers with a high concentration of solvents.

System Operation

The Boxxer heat exchanger system is a highly engineered cleaning plant designed by HydraMaster Corporation. The system utilizes a dynamic heating system comprised of two separate exhaust heat exchangers for capturing "free heat."

The water flow is as follows:

Water is fed into the machine under tap pressure and it flows through the water conditioner to the water box. The solution is then picked up by the high pressure pump and pressurized to the desired level. The water then splits flow, as demanded by the technician.

The majority of the water flows to the bypass valve assembly, then back to the water box. The water demanded by the technician flows from the water pump through the blower exhaust heat exchanger then through the engine exhaust heat exchanger and out to the cleaning tool.

When the cleaning solution reaches a preset high temperature, it is released from the system and directed to the recovery tank. Then cool water enters the system to regulate the temperature. When equipped with an engine exhaust diverter, the diverter bypasses the heat from the exhaust heat exchanger and simultaneously releases water from the system and directs it to the recovery tank.

As there is no guess work in the manufacture of these highly advanced cleaning plants, there must be none in preparing it to get the job done in the field. It is the purpose of this manual to help you properly understand, maintain and service your cleaning plant. Follow the directions carefully and you will be rewarded with years of profitable, trouble-free operation.

It is imperative that no section be overlooked when preparing for operation of this equipment.

Machine Specifications

Frame:	26"W x 45"L x 41"H Aluminum Cast with Baked-on Epoxy Finish
Weight:	807 lbs.
Engine:	Vanguard 27HP Briggs and Stratton Pressurized Oil System Spin-on Filter, Oil Cooler and Oil PSI Protection Switch
Ignition:	Electronic, Keystart
Vacuum Blower:	Dominator 4007, Tuthill/M-D Tri-Lobe,
Pump:	Comet FW5530S, 55 GPM Hot Seals, 3000 PSI
Chemical System:	Last-Step Chemical
Operating Pressure:	Up to 1,200 PSI
Heating System:	1 Water to Water Copper Shell and Tube Heat Exchanger 1 Copper Cross Flow Heat Exchanger Blower/Engine Exhaust
Instruments:	Water Pressure Gauge, Liquid Filled, 0-1500 PSI Hour Meter, Machine Runtime Keyed Ignition, Start/Stop Chemical Flowmeter, Clear Acrylic, 0-10 GPH Vacuum Gauge Temperature Gauge

- Recovery Tank:** 70 Gallon Aluminum, Epoxy Finish
- Cleaning Wand:** Stainless Steel
Replaceable Grip
Rebuildable Solution Valve
- High Pressure Hose:** ¼" High Temperature Lined/Vinyl Covered
Hose Rated to 2250 PSI
- Vacuum Hose:** 2" Reinforced, 1½" Reinforced.
- Standard Equipment:** Machine Power Console
Full Instrumentation
Tuthill/M-D Tri-Lobe Vacuum Blower
Boxxer™ Water Heating Package
Vacuum Recovery Tank
Carpet Cleaning Wand
Chemical Jug
150 ft, 2" Vacuum Hose
10 ft, 1-½" Wand Whip Line
150 ft, Super Flex Solution Line
Battery Box
Van Decal Package
Van Installation Kit
Operation Manual
HydraMaster Jacket

Spare Parts Recommendation

Downtime in the unit can be very expensive, because your truckmounted unit is capable of generating several hundred dollars per day. In order to minimize such downtime, it is strongly recommended by the manufacturer that you purchase and keep in your truck the parts listed below.

Parts Orders

To expedite your parts needs, please call your sales representative. In most instances, he either stocks or has access to parts through a regional service center. If further assistance is needed, contact the factory and coordinate your needs. If this becomes necessary, always indicate the method of shipment you desire, i.e. UPS, Blue Label, Air Freight, Air Express, etc.

HydraMaster Parts Dept. Phone (425) 775-7276

HydraMaster Parts Dept. Toll Free Fax 1-800-426-4225

Spare Parts List (078-340)

PART NO	DESCRIPTION	QTY
010-054	Belt, A38 Pump	1
046-010	Diaphragm, Chemical Pump	1
049-002	Filter, Fuel	1
049-008	Filter, S/S Vacuum Pump, 2½"	1
049-014	Filter, Vanguard Oil	2
049-016	Filter, ¼" Replacement Y	1
049-023	Screen, Garden Hose	1
TBD	Filter, Vanguard Air	1
049-118	Filter, ¼" s/s	1
049-030	Filter Bag, 92 + Truck Mount	2
052-050	Quick Connect, 440 Male	3
052-051	Quick Connect, 440 Female	2
052-052	Quick Connect, 660 Male	1
052-053	Quick Connect, 660 Female	1

Spare Parts List (078-340)

PART NO	DESCRIPTION	QTY
056-001	Fuse, 10 amp	2
056-008	Fuse, 15 amp	2
056-010	Fuse, 25 amp	1
074-007	Gauge, Hi PSI (0-1500)	1
074-032	Meter, Chemical Flow	1
TBD	Kit, Seal & Spring Hi PSI	1
TBD	Kit, Comet Seal	1
106-016	Plug, Vanguard Spark	2
106-045	50 Series Element	8
157-080	Switch, s/s Float	1
157-040	Rocker	
157-022	Switch, Relay	2
169-017	Valve, 3-way Chemical	1
169-022	Valve, 1 ½" Full Port	1
169-155	Check Valve, Last-Step Chemical	2
169-160	Valve, 2-way Chemical Metering	1
180-004	Orifice, Primary	1

NOTE:

Engine Oil: **30 weight** motor oil with a minimum standard of SE, SF, SG.
Blower Oil: 40 weight **non detergent**
Pump Oil: 40 weight **non-detergent**

Responsibilities

The Purchaser's responsibilities are:

Prior to arrival of unit, install $\frac{5}{8}$ " exterior plywood flooring in the vehicle and cover it with artificial turf or apply a spray-on coating such as Rhino-lining™ to the van floor.

CAUTION

In Dodge vans the fuel tanks are located directly against the floor. Caution must be used when drilling any holes through the floor. (See Product Support Bulletin 94062 at the end of this manual.)

To purchase heavy duty 24- 60 amp hour battery and have the battery 'slow' charge if new.

CAUTION

If the battery is not fully charged, damage can occur to the engine charging regulator.

Reading of owner's manual: It is the purchaser's responsibility to read the unit operation manual and to familiarize himself with the information contained therein.

*Special attention should be paid to all **Cautions** and **Warnings**.*

The **Sales Representative's** responsibilities are:

ACCEPTANCE OF SHIPMENT:

1. If the unit shows any outward signs of damage, do not sign the delivery receipt until you have closely inspected the unit and noted any damage on the delivery receipt.
2. The salesman from whom you purchased your unit is responsible for supervising the correct installation of the unit in your vehicle and thoroughly training you in its operation, maintenance and precautions.

CORRECT INSTALLATION INCLUDES:

- Vehicle of proper load carrying capacity (recommendation: 3/4 ton).
- Installation of a safe fuel tap system and through-floor fittings as approved by Hydramaster
- Placing the unit and recovery tank in your vehicle and securing them with bolts or tie down cleats.
- Connecting gasoline lines.
- Connecting the battery.
- Checking the pump, vacuum blower and engine oil levels prior to starting the unit.
- Starting the unit to check the engine and see that all systems function normally.
- Checking all hoses, wands, etc. for correct operation.

TRAINING:

- A thorough review of the operation manual with purchaser.

Instruction and familiarization in:

- How to correctly start up and shut down the unit.
- How to correctly clean with the unit.
- Where and how often to check and change component oil levels.
- How the unit's systems work.
- How to troubleshoot the unit.
- How to do basic repairs.
- Safety precautions and their importance.
- Freezing damage and how to avoid it.
- Hard water damage and how to avoid it.
- A thorough review of the unit warranty and warranty procedures.
- A thorough review of hard water precautions and warnings.
- How to determine hard water areas.
- Use of water softening systems.

Vehicle Preparation

When selecting a truck, remember the preferable vehicle for a Boxxer 427 installation is a cargo van with a heavy-duty suspension package and a half ton capacity. If a fresh water tank is added, a three quarter ton or larger capacity van, with a 2,400 pound payload capacity, is required.

TRUCK PREPARATION

The manufacturer recommends the installation of a spray-on bed liner in the vehicle prior to installation of machine.

CAUTION

Be cautious when drilling any holes through the van floor. Many vans have critical components mounted directly below the van floor that could be damaged by a misplaced drill bit. (See Product Support Bulletins 92101, 94062, and 94063 at the end of this manual.)

This provides 'metal to cushion' mounting rather than 'metal to metal' and makes for an attractive van interior. It is highly recommended to install roof vents in vehicles operated in hot weather locations. Roof vent positions are shown in Figure 1-1.

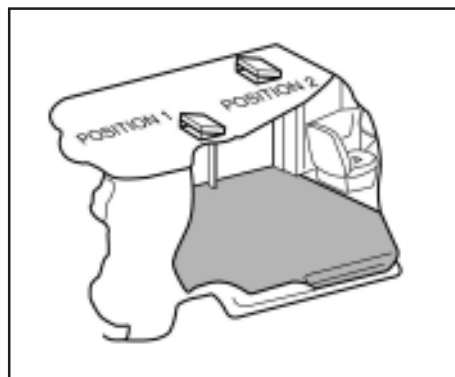

Figure 1-1 Roof Vent

PLACEMENT OF UNIT IN VEHICLE

There are two recommended unit placements:

SIDE DOOR:

Most installations are side door. This provides rear access for accessories and hoses as well as unobstructed access to the component/working side of the machine, thus making it a bit easier to perform maintenance and/or repair without removing the unit from the truck.

REAR DOOR:

Although this location partly limits working access, it does direct the noise away from the cleaning site. Some cleaners in the colder areas prefer this location because it puts the weight over the rear wheels for better traction in ice and snow. Rear mounting requires the unit to be slid to the right side as far as possible.

This not only provides adequate working space on the component side of the unit but also improves weight distribution inside the van (engine and component weight line up over drive shaft). Also, it is physically easier to load the unit into the rear door due to the height of the van bed.

Figure 1-3 Recommended Placement

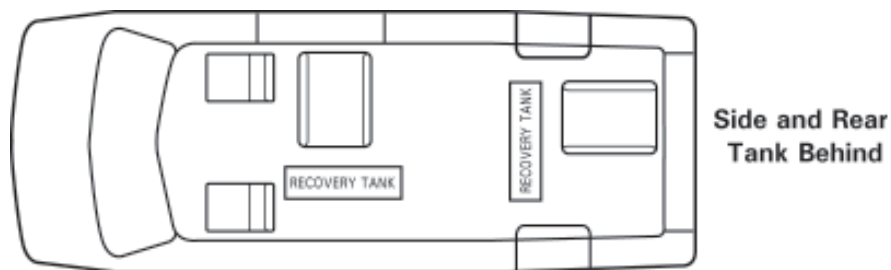

Machine Tie Down Cleats

Secure the machine to the floor of the van with the four tie down cleats provided. This safety measure will ensure that the machine will not slide inside the van. See the following illustration for the correct installation.

Figure 1-4 Installation Using Tie-down Cleats

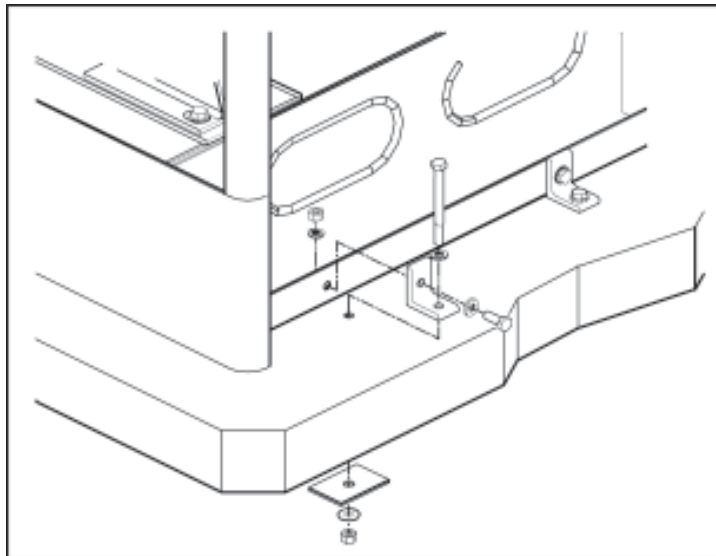

Ensure that the machine is well secured to the floor of the van with the hardware supplied. A sudden or crash stop will cause the machine to rocket forward. Protect yourself and the machine. **SECURE IT!**

WARNING

It is recommended by the manufacturer that the exhaust from the front of the machine be vented down under the truck to prevent carbon monoxide from entering the job site. **Always park the truck so the exhaust is blowing away from the job site.**

The manufacturer also recommends the installation of aluminum vents in the truck roof to allow heat to escape.

WARNING

Never operate this machine with a portable gas can inside the truck. Doing so increases the risk of a fire or explosion.

Mount a fire extinguisher just inside the rear or side door for emergencies.

 **WARNING**

Do not use a portable propane tank inside of the truck or van. It is dangerous and illegal in most states.

 **WARNING**

Transportation in a vehicle of any vented fuel container that presently holds or has ever held a flammable liquid is strictly forbidden by HydraMaster Corporation and by federal and state regulation.

 **WARNING**

The engine exhaust from this product contains chemicals known to the State of California to cause cancer, birth defects or other reproductive harm.

High Altitude Operation Preparation

To have your machine run at it's peak performance; you may have to make adjustments depending on the elevation. Elevation plays a key role in how the machine will operate.

The factory setting of the machine is set for elevations from 0—3,000 feet. Any time the machine is operated above 3,000 feet there are two areas on the machine the *may* need adjustment.

The first area is the carburetor jet. The higher the elevation, the less air is provided to the fuel mixture. This will make the engine run 'rich', and, in turn will result in the loss of power, excessive heat in the exhaust, and carbon buildup in the exhaust and heat exchanger system. The jet sizes vary per engine and elevation. Consult HydraMaster to obtain proper jet size.

The second area that may need adjustment is the heat control system. The heat control system is also optimized to 0-3,000 feet. At higher altitudes the boiling point of water is lowered. In turn, this can cause the water box to boil and the high pressure pump to cavitate. The heat control system settings will have to be adjusted to compensate for the elevation. These settings will vary according to elevation. Contact HydraMaster to obtain the recommended settings.

Local Water Precautions

The quality of water varies greatly. Many areas have an excess of minerals in the water which results in what is commonly called "hard water." These minerals tend to adhere to the insides of heater coils and other parts of the machines causing damage and a loss of cleaning effectiveness. This influences the reliability and efficiency of equipment in direct proportion to the level of hardness.

HARD WATER ADVISORY

HydraMaster recognizes that any hard water deposits which might occur within the water system of our truckmounts is a serious problem. The precision technology of truckmount heat exchanger systems is intolerant of any foreign material. Hard water deposits will ultimately decrease the performance of the system and are expected to seriously lower the reliability of the machine.

To validate a machine's warranty, HydraMaster requires that all machines operating in designated "Hard Water Areas" (3.5 grains or more per gallon) be fitted with a water softening system or a properly installed magnetic-type de-scaler must be used and maintained. Periodic de-scaling or acid-rinsing alone is not adequate in these areas.

HydraMaster does not recommend any particular type or brand, however the relative effectiveness of some types of magnetic de-scalers or softeners may require additional periodic use of de-scaling agents.

HydraMaster also recommends, in the strongest possible terms, that machines in all areas be fitted with a water softening system for improved operation and reliability.

HydraMaster has included five hard water test strips with your machine. These can be used to test the water in your immediate and surrounding areas as they can vary greatly. Assume all water obtained from wells is hard.



Failure to take appropriate measures to prevent scale build up can result in **system failure and loss of warranty** on affected parts.

HARD WATER AREA MAP

The following map defines areas in the United States which compromise fluid related components such as hoses, fittings, heaters, pumps, valves and water cooled engines. For other countries, hard water area maps can be obtained from geological societies.

WATER SOFTENER

Cleaning efficiency and equipment life is increased, chemical use decreased, and the appearance of cleaned carpets enhanced when water softeners are incorporated in hard water areas. The manufacturer strongly urges the use of water softener units in areas exceeding 3½ grains per gallon. Failure to use a water softener in these areas will invalidate the machine's warranty. Using a hard water area map as a reference, determine the quality of water in your area and take action immediately, if necessary.

Reports from several of our machine users commending the results of the use of water softeners in conjunction with their machines prompts us to recommend the procedure to everyone in a "hard water" area.

The relatively low cost of a water softener service is more than made up for by an increased life of machine parts, reduced chemical costs and continued cleaning efficiency. The water softener will also increase the effectiveness of the cleaning chemicals, therefore less chemical will be needed.

Contact a water softener distributor in your area for information on the rental of a simple water treatment unit to carry in your truck. Be sure to change the water softener in accordance with the capability of the softener. For example: If the softener will treat 900 gallons of water and the machine uses an average of 30 gallons per hour, for an average of 5 hours a day, this equals 150 gallons per day. In 6 days the machine would use 900 gallons of water. Therefore, the softener would need to be changed every 6 working days for maximum softening.

WASTE WATER DISPOSAL ADVISORY

There are laws in most communities prohibiting the dumping of recovered "gray" water from carpet cleaning in any place but a sanitary treatment system.

This cleaning rinse water, recovered into your unit's vacuum tank, contains materials such as detergents. These must be processed before being safe for streams, rivers and reservoirs.

IN ACCORDANCE WITH THE EPA, STATE AND LOCAL LAWS, DO NOT DISPOSE OF WASTE WATER INTO GUTTERS, STORM DRAINS, STREAMS, RESERVOIRS, ETC.

In most cases, an acceptable method of waste water disposal is to discharge into a municipal sewage treatment system after first filtering out solid material such as carpet fiber. Access to the sanitary system can be obtained through a toilet, laundry drain, RV dump, etc. Permission should first be obtained from any concerned party or agency.

One disposal method which usually complies with the law is to accumulate the waste water and haul it to an appropriate dump site. Another solution to the disposal problem is to equip yourself with an Automatic Pump-Out System. These systems are designed to remove waste water from the extractor's recovery system and actively pump the water through hoses to a suitable disposal drain. Properly designed, they will continuously monitor the level of waste water and pump it out simultaneously to the cleaning operation. The hidden benefit of this process is that the technician does not have to stop his cleaning to empty the recovery tank.

HydraMaster makes an A.P.O. System available which can be ordered with new equipment or installed later.

The penalties for noncompliance can be serious. Always check local laws and regulations to be sure you are in compliance.

This page intentionally left blank

Figure 1-5 Hard Water Map

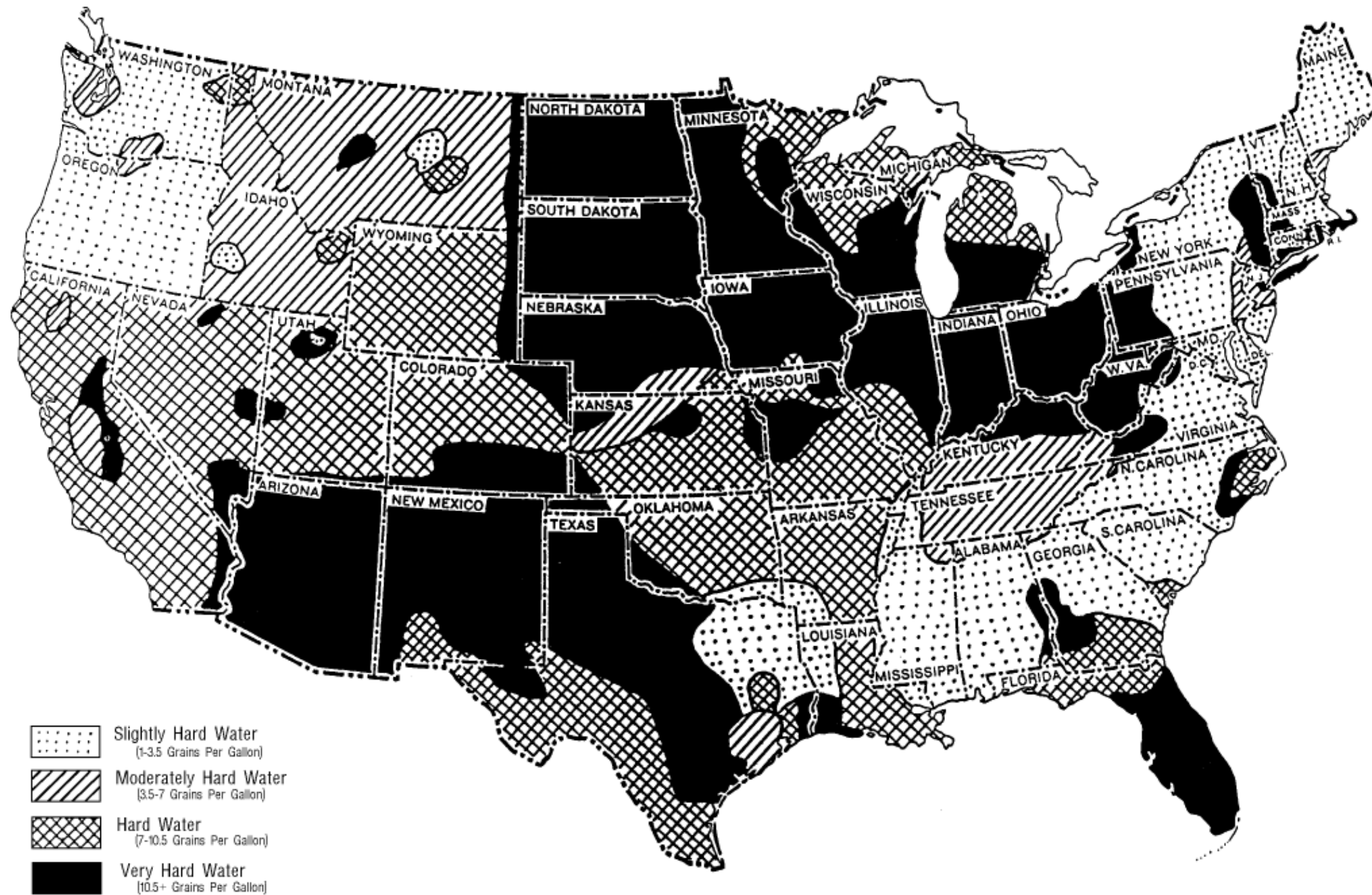

Source: Water Treatment Fundamentals, Water Quality Association, 1996.

Machine Assemblies and Parts Lists

Figure 1-6 Machine Assembly - Front View - Left Side
D-5570 Rev B

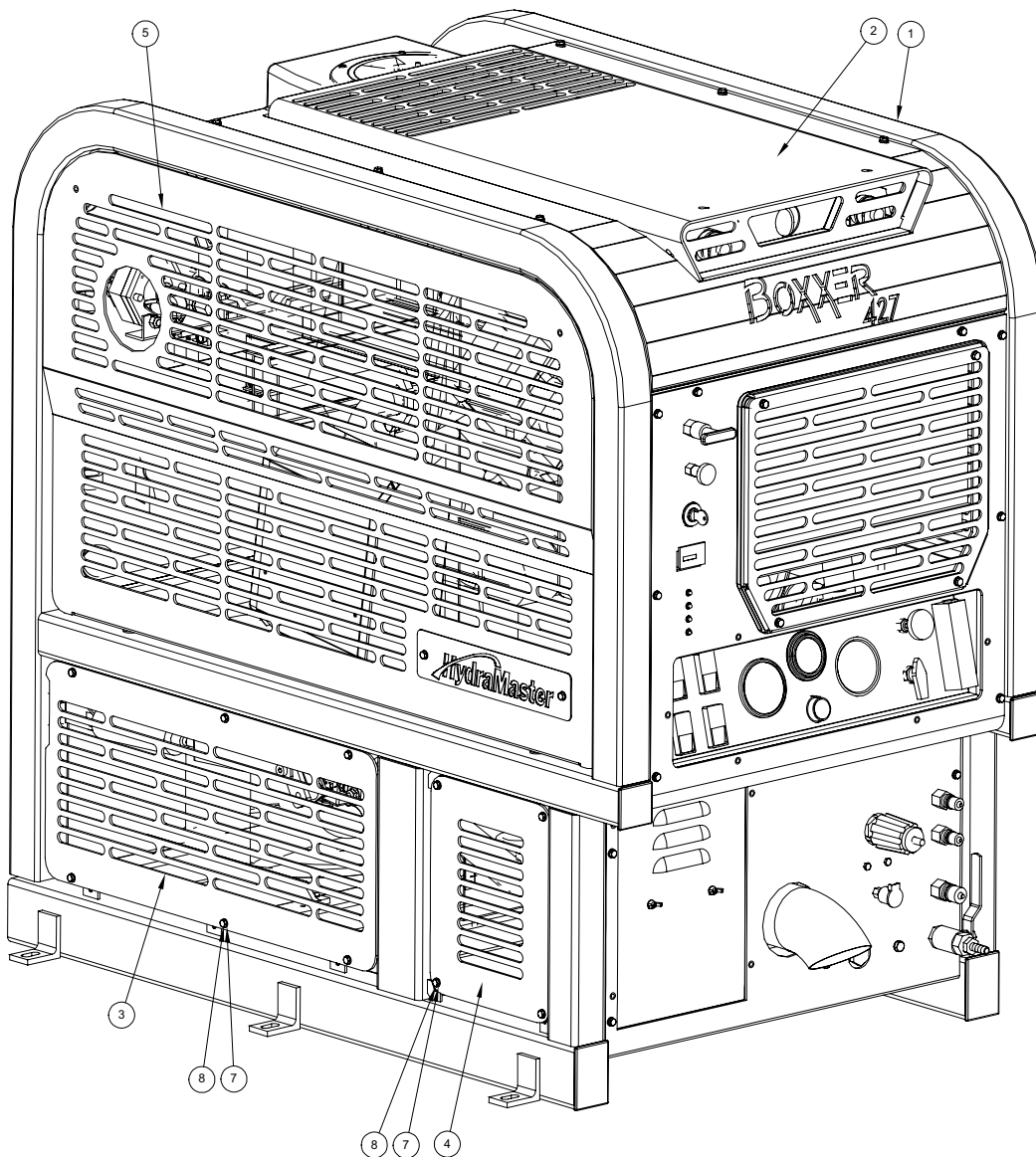

Figure 1-7 Machine Assembly - Front View - Right Side
D-5570 Rev B

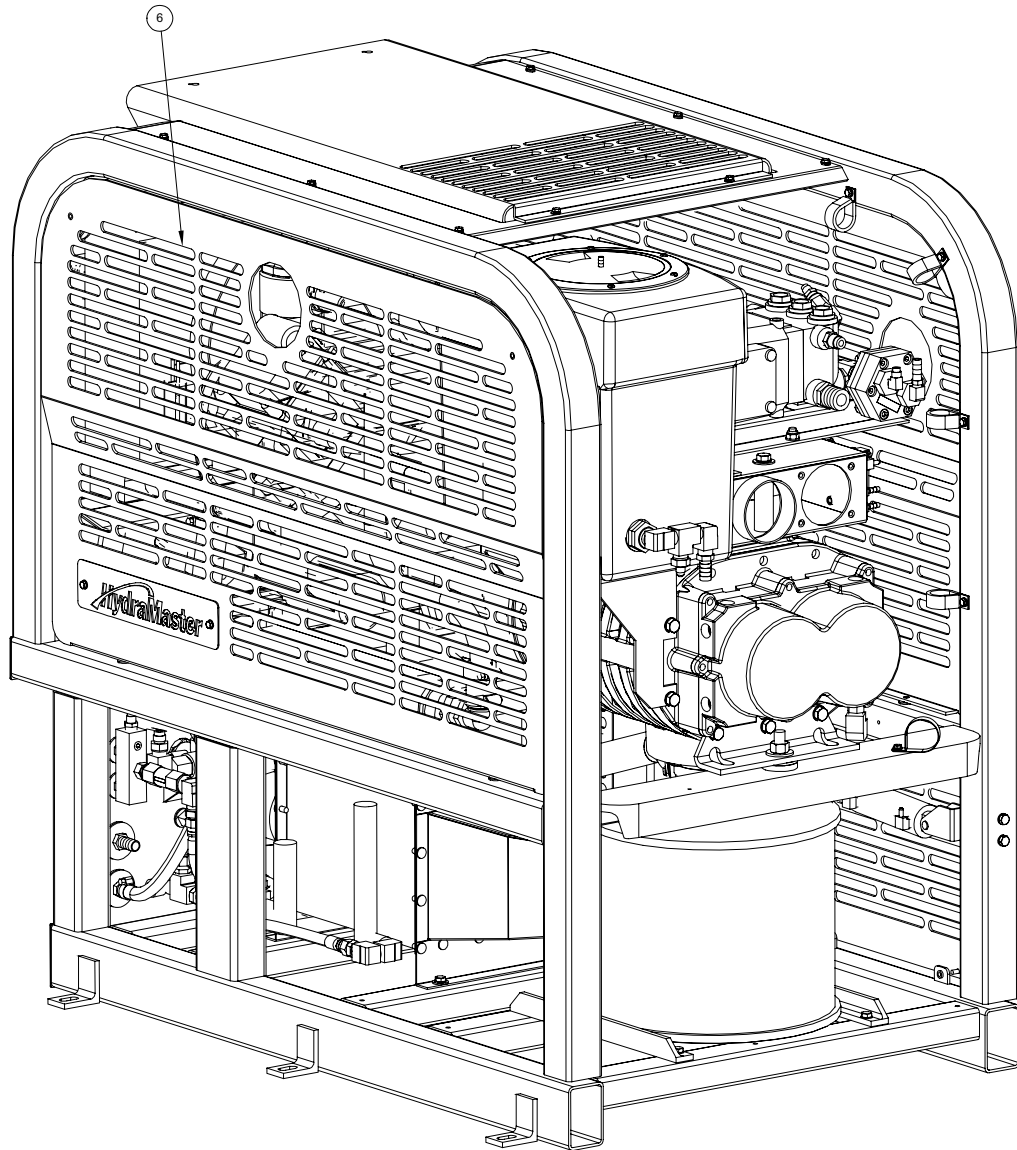
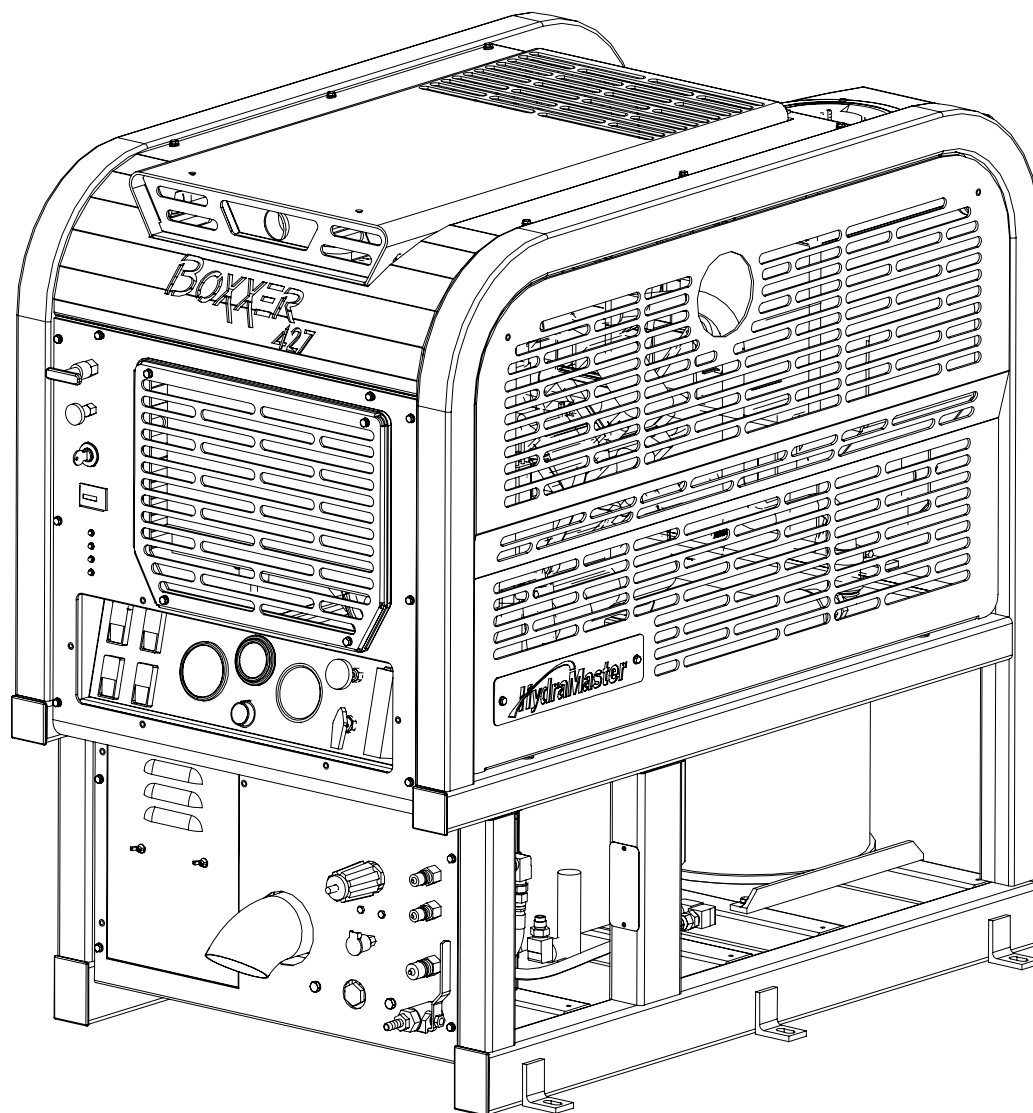

Figure 1-8 Machine Assembly - Rear View - Right Side
D-5570 Rev B



Machine Assembly Parts List

Item	Part Number	Description	Qty
1	610-001-033	Assembly, Frame - Boxxer 427 (Fig. 1-9 - 1-11)	1
2	610-050-033	Assembly, Top Cover - Boxxer 427 (Fig. 1-31)	1
3	000-041-424	Cover, Lower Left Side - Rear - Boxxer 427	1
4	000-041-426	Cover, Lower Left Side - Front - Boxxer 427	1
5	610-050-033	Assembly, Machine Left Side Cover (Fig. 1-33)	1
6	610-050-033	Assembly, Machine Right Side Cover (Fig. 1-32)	1
7	000-174-001	Washer, #10 Flat	10
8	000-143-126	Screw, #10-24UNC x 0.50" Lg. Hex Head	10

Figure 1-9 **Frame Assembly - Front View - Left Side**
D-5571 Rev D

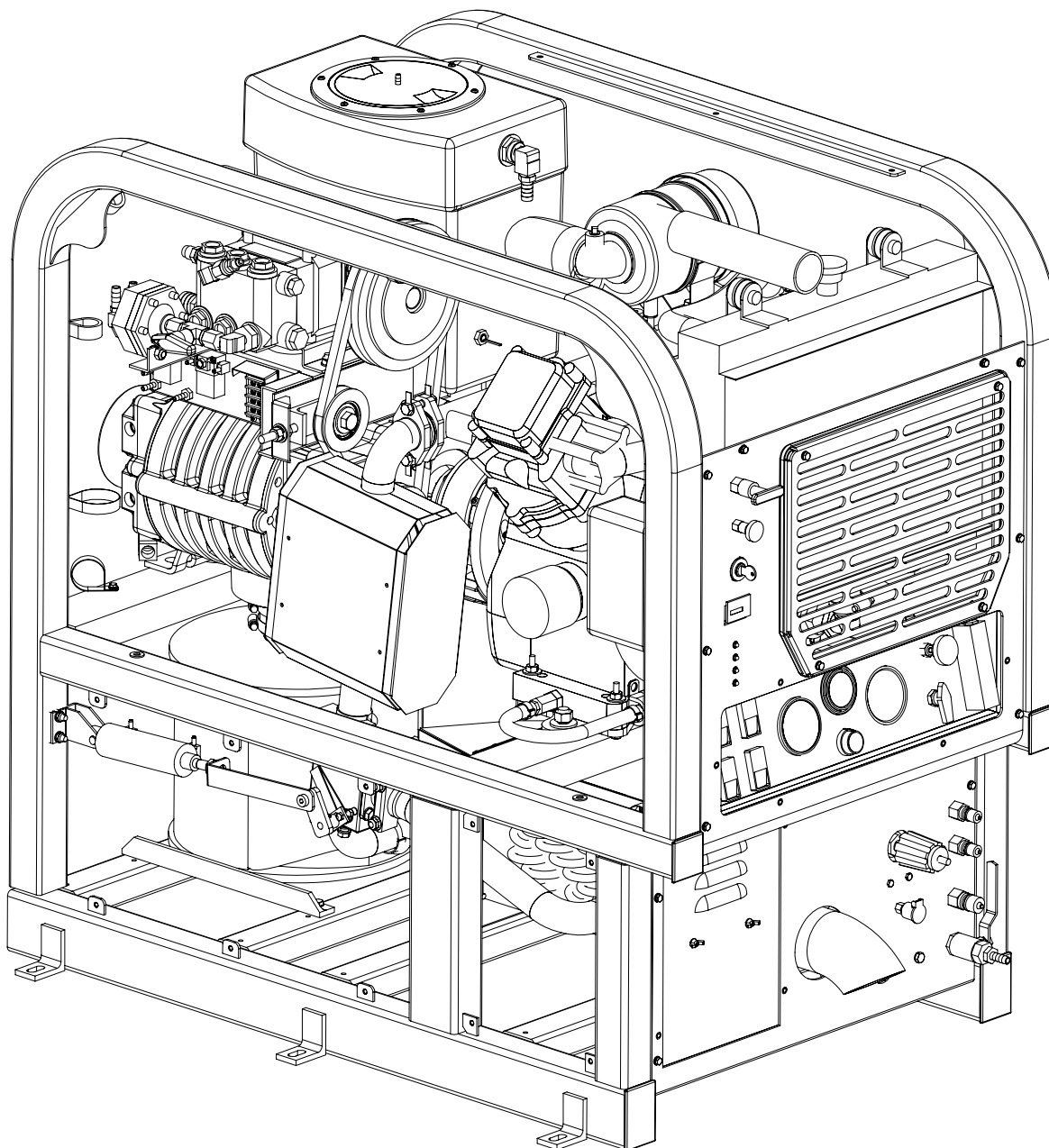
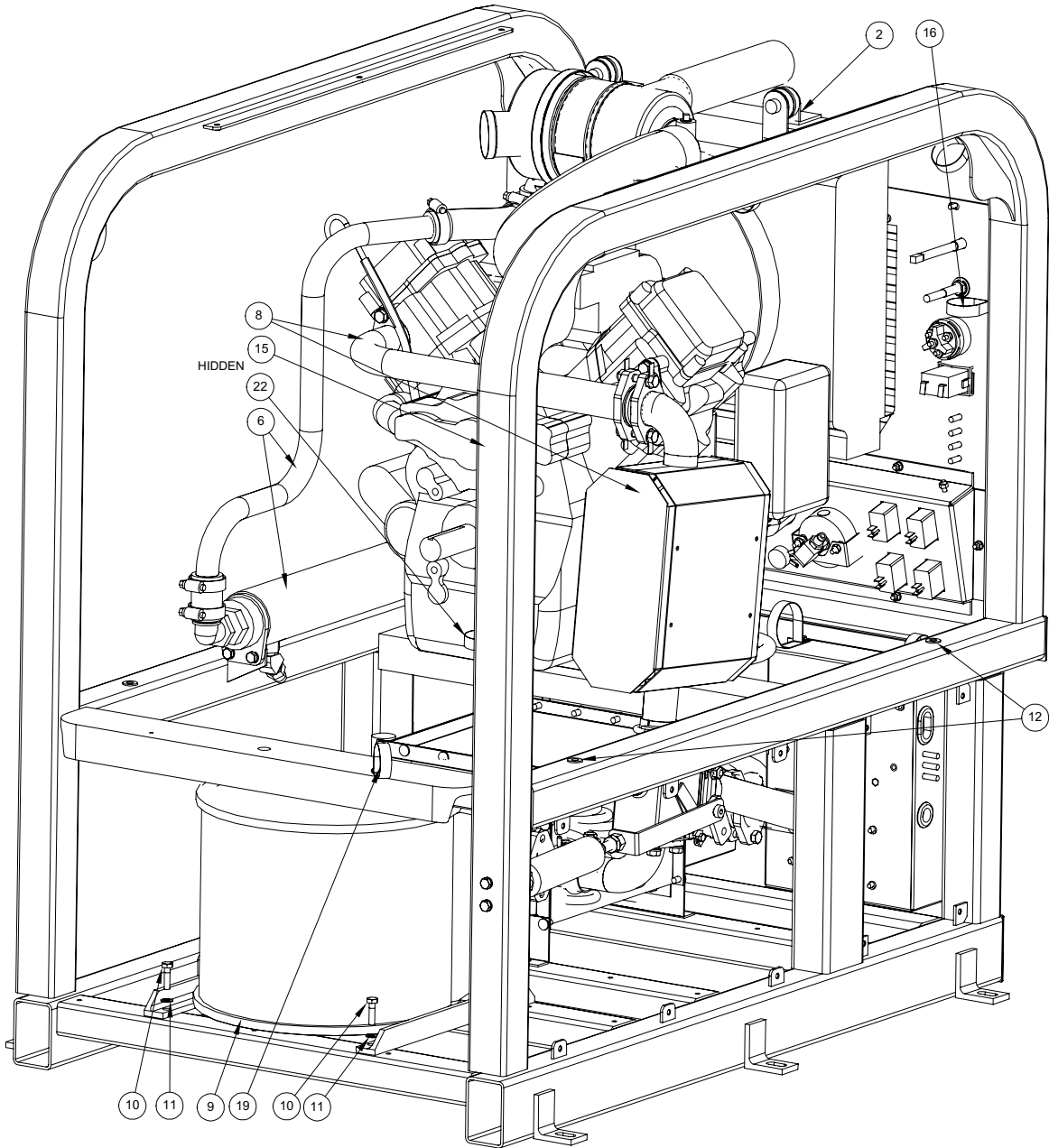
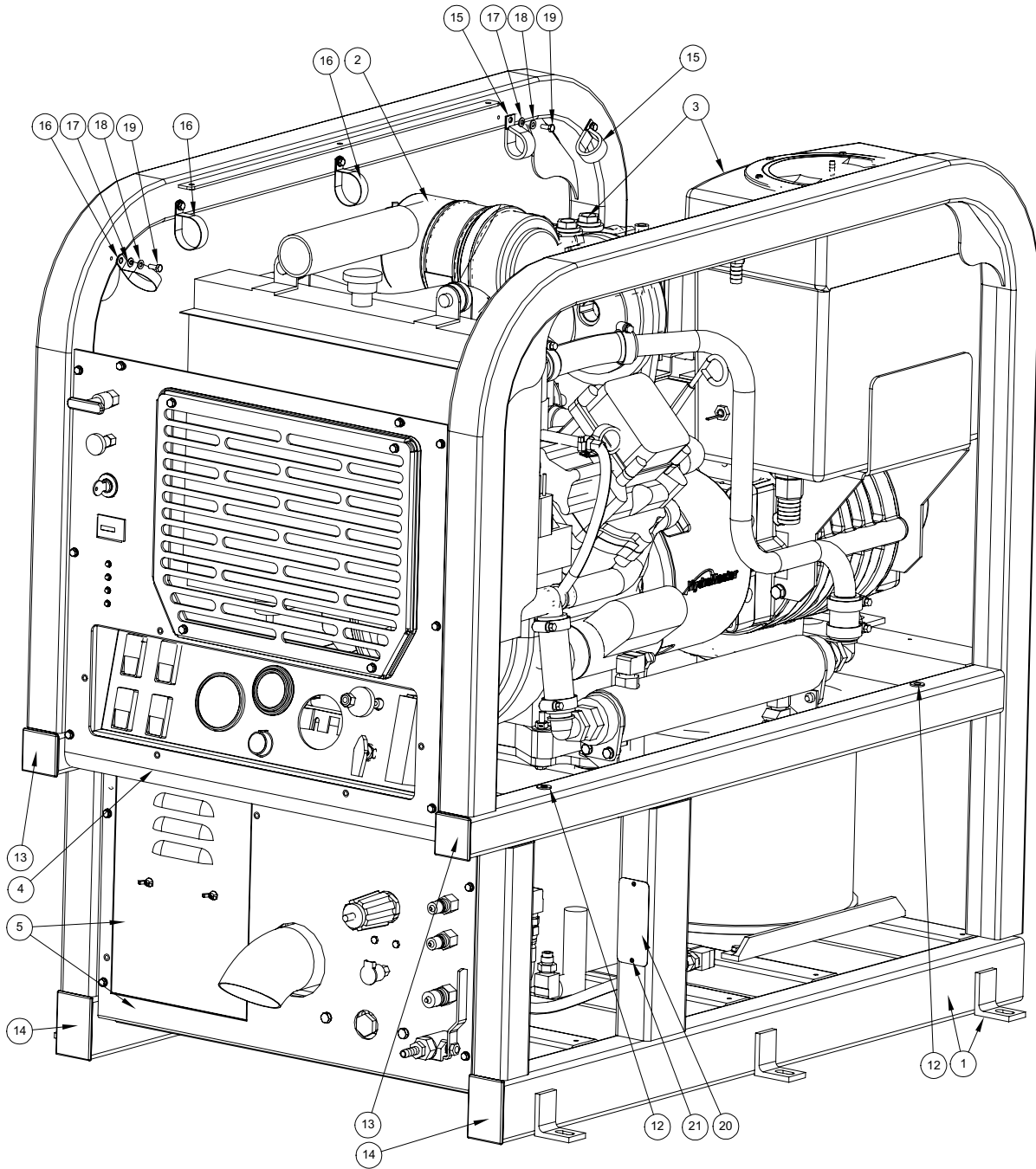

Figure 1-10 Frame Assembly - Front View - Right Side
D-5571 Rev D



ITEM 3 SUPRESSED IN THIS VIEW

Figure 1-11 Frame Assembly - Rear View - Left Side
D-5571 Rev D



Frame Assembly Parts List

Item	Part Number	Description	Qty
1	000-055-168	Frame, Steel - Welded - Boxxer 427	1
2	610-003-033	Assembly, Engine - Boxxer 427 (Fig. 1-12 - 1-13)	1
3	610-002-033	Assembly, Blower - Boxxer 427 (Fig. 1-16)	1
4	610-020-033	Assembly, Dash Upper - Boxxer 427 (Fig. 1-21 - 1-22)	1
5	610-019-033	Assembly, Dash Lower - Boxxer 427 (Fig. 1-24 - 1-25)	1
6	610-006-033	Assembly, Coolant Heat Exchanger (Fig. 1-29)	1
7	610-005-033	Assembly, Blower Heat Exchanger (Fig. 1-30)	1
8	610-003-033	Assembly, Exhaust - Boxxer 427 (Fig. 1-14)	1
9	000-093-092	Silencer, Boxxer 427 - Weldment	1
10	000-143-002	Screw, 1/4"-20UNC x 1.00" Lg. Hex Head	4
11	000-174-019	Washer, 1/4" Lock	4
12	000-020-063	Bushing, Snap, 0.55" O.D. x 0.312" I.D.	4
13	000-027-109	Cap, 2" x 2" Black	2
14	000-027-110	Cap, 2" x 3" Black	2
15	000-033-057	Clamp, 1" Cushion Loop	3
16	000-033-053	Clamp, 1-1/2" Cushion Loop	5
17	000-155-054	Spring, #10 Belleville Washer	9
18	000-174-001	Washer, #10 Flat	9
19	000-143-126	Screw, #10-24UNC x 0.50" Lg. Hex Head	9
20	000-105-012	Plate, Machine Serial I.D.	1
21	000-140-001	Rivet, 1/8" x 1/4" Aluminum	2
22	000-033-067	Clamp, 2" Cushion Loop	1

Figure 1-12 Engine Assembly - Rear View
D-5572 Rev G

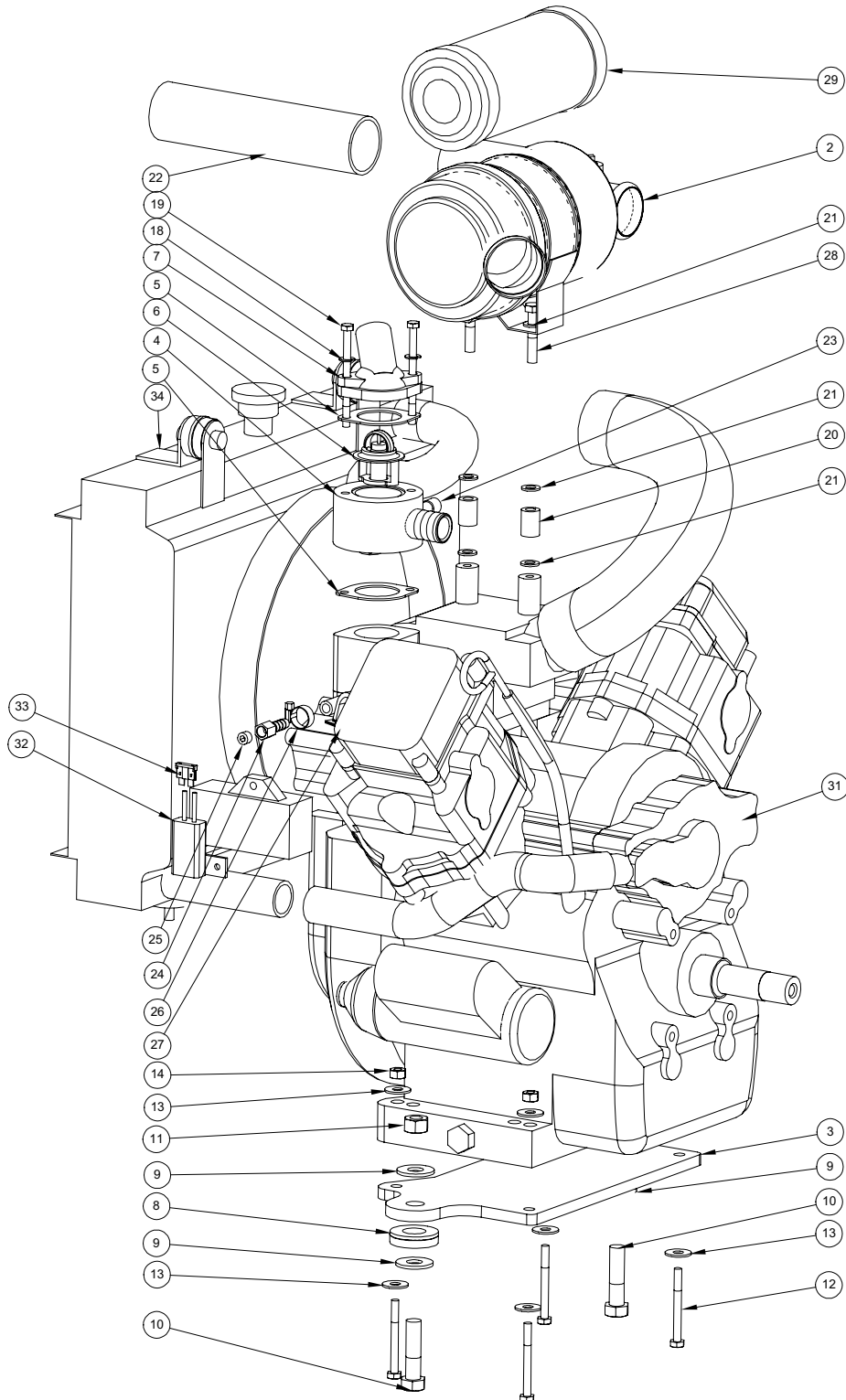
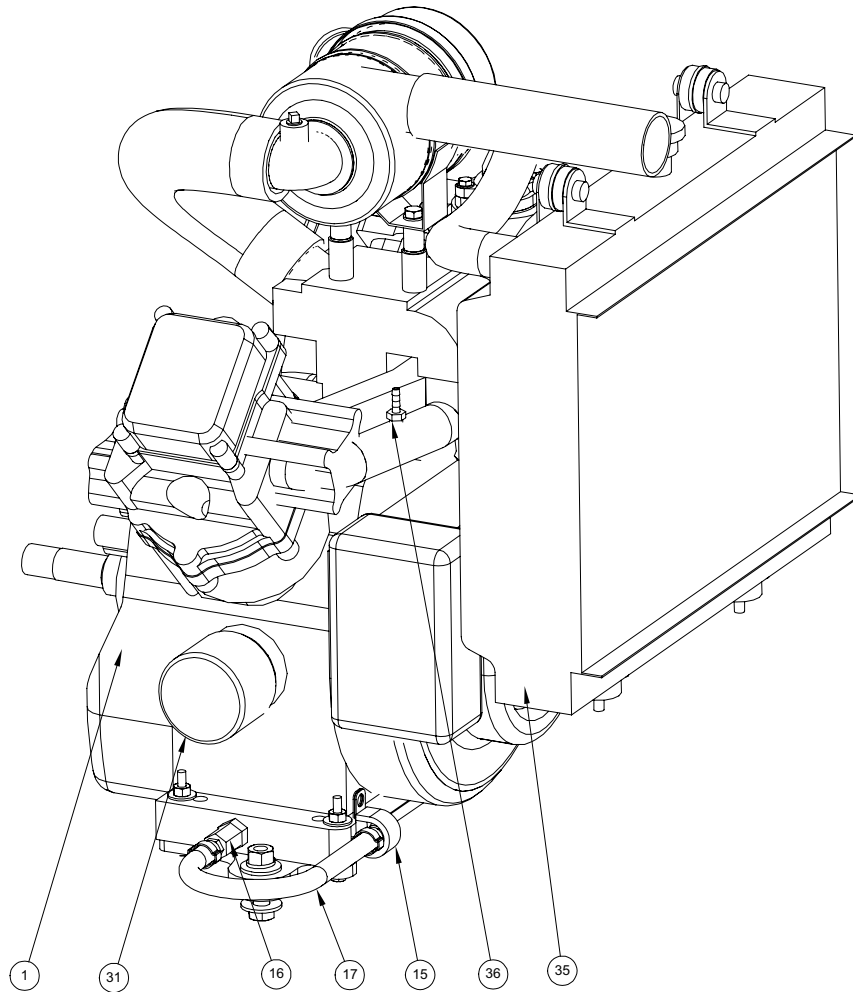

Figure 1-13 Engine Assembly - Front View
D-5572 Rev G



Engine Assembly Parts List

Item	Part Number	Description	Qty
1	000-047-026	Engine, Briggs & Stratton 27HP	1
2	000-042-011	Housing, Air Cleaner - Daihatsu Engine	1
3	000-092-011	Mount, Engine 27 B&S - Boxxer 427	1
4	000-001-033	Adapter, Thermostat Housing	1
5	000-057-050	Gasket, Thermostat Housing Daihatsu Engine	2

Engine Assembly Parts List

Item	Part Number	Description	Qty
6	000-047-026	Thermostat, Stock B&S 27HP	1
7	000-047-026	Thermostat Housing, B&S 27 HP Stock	1
8	000-174-105	Washer, 1-1/16" I.D. Self Aligning Spherical 2 Pc Set	2
9	000-174-007	Washer, 1/2" Flat	4
10	000-143-567	Screw, 1/2"-13UNC x 2.0" Lg. Hex Head Grd. 8	2
11	000-094-037	Nut, 1/2"-13UNC Hex 2-Way Locking - Z/P	2
12	000-143-568	Screw, 5/16"-18UNC x 2.50" Lg. Hex Head Grade 8	4
13	000-174-004	Washer, 5/16" Flat	8
14	000-094-081	Nut, 5/16"-18UNC Hex 2-Way Locking	4
15	000-033-117	Clamp, 1" Cushion Loop w/ 7/16" Mount Hole	1
16	000-052-063	Bushing, 14mm x 1/4" NPT Engine Oil Drain Adapter	1
17	000-068-746	Hose, Engine Oil Drain - Boxxer 427	1
18	000-174-019	Washer, 1/4" Lock	2
19	000-143-569	Screw, 6mm x 85mm Lg. Hex Head	2
20	000-154-144	Spacer, Air Cleaner - Boxxer 427	2
21	000-174-049	Washer, 5/16" Flat	6
22	000-068-702	Hose, 1-3/4" I.D.	1
23	000-106-007	Plug, 1/4" NPT Allen Head	1
24	000-052-108	Insert, #F25 (1/8" FPT x 5/16" Barb)	1
25	000-106-009	Plug, 1/8" NPT Allen Head	1
26	000-033-005	Clamp, Size #5 Hose	1
27	000-033-057	Clamp, 1" Cushion Loop	1
28	000-143-184	Screw, 8mm x 45mm Lg. Hex Head Grd. 10.9	2
29	000-049-063	Filter, Replacement - Engine Air Daihatsu	1
30	000-049-014	Filter, 16HP Oil - All B & S	1
31	000-111-171	Pump, B&S 27 HP Water	1
32	000-056-006	Fuse Holder, Inline Weather Proof	1
33	000-056-011	Fuse, 30 AMP Plug In	1
34	000-113-007	Radiator, 27 B & S Engine	1
35	000-052-293	Insert, #23 (1/8" NPT x 3/16" Barb)	1

Figure 1-14 Exhaust Assembly
D-5580 Rev C

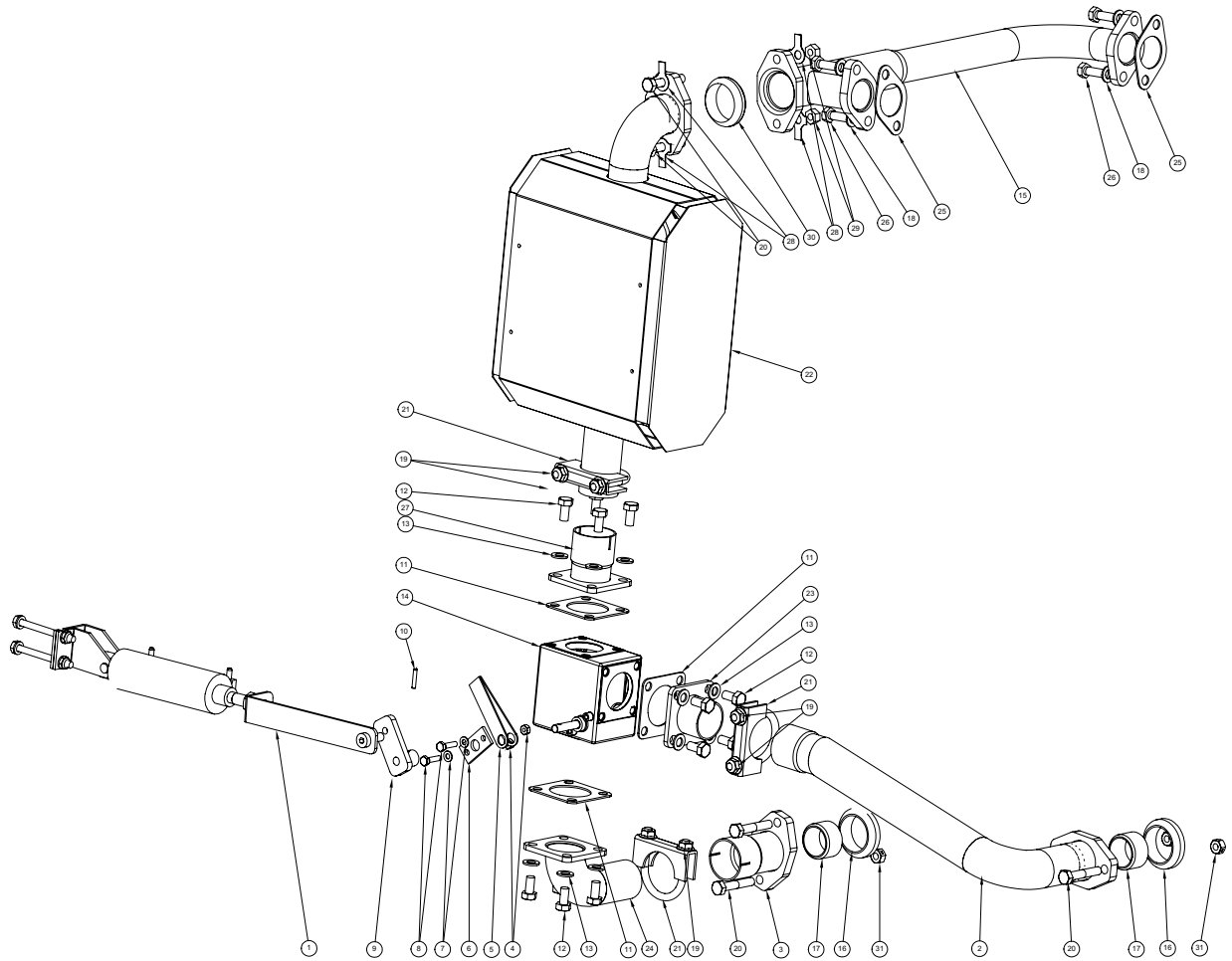

Exhaust Assembly Parts List

Item	Part Number	Description	Qty
1	Fig. 1-15	Assembly, Diverter Valve Actuator - Boxxer 427	1
2	000-125-214	Tube, Diverter To Outlet Plenum - Boxxer 427	1
3	000-001-116	Adapter, 1.50" F Slip To Flare - Boxxer 427	1
4	000-094-027	Nut, #10-24UNC Hex	2
5	000-155-030	Spring, Leaf	1
6	000-138-010	Retainer, Leaf Spring	1
7	000-174-001	Washer, #10 Flat	2
8	000-143-132	Screw, #10-24UNC x 0.75" Lg. Hex Head	2
9	000-015-631	Bracket, Air Cylinder Actuation	1
10	000-103-014	Pin, 1/8 x 3/4" Roll	1
11	000-057-146	Gasket, Four Hole Exhaust Diverter	3
12	000-143-572	Screw, 5/16"-18UNC x 5/8" Lg. Hex Grd. 5	12
13	000-174-069	Washer, 5/16" Inconel Belleville, Diverter Valve	12
14	000-169-045	Valve, Cast Exhaust Diverter	1
15	000-090-059	Manifold, Boxxer 427 Engine Exhaust B&S 27 Hp	1
16	000-057-177	Gasket, Exhaust Donut 1.50"	2
17	000-125-128	Tube, 1-3/8" OD x 1/8" Wall x 7/8" Long	2
18	000-174-049	Washer, 5/16" Flat	4
19	000-094-117	Nut, 5/16"-18UNC Hex Spiralock	6
20	000-143-124	Screw, 5/16"-18UNC x 1.75" Lg. Hex Head	6
21	000-033-068	Clamp, 1-1/2" Muffler	3
22	000-093-100	Muffler- Weldment - Boxxer 427	1
23	000-001-102	Adapter, Exhaust Flange To 1.50" M Slip	1
24	000-052-642	Elbow, 1.50 With Flanges	1
25	000-057-194	Gasket, B&S 27 Hp Exhaust Manifold - Boxxer 427	2
26	000-143-187	Screw, 8mm x 25mm Lg. Grade. 10.9 Hex Head	4
27	000-001-099	Adapter, Exhaust Flange To Ø1.50" F Slip - Boxxer 421	1
28	000-174-166	Washer, 5/16" Tab	4
29	000-094-012	Nut, 5/16-18"UNC Hex	2
30	000-057-199	Gasket, Exhaust Donut	1
31	000-094-081	Nut, 5/16"-18UNC Hex 2-Way Locking	4

Figure 1-15 Diverter Valve Actuator Assembly
C-5584 Rev B

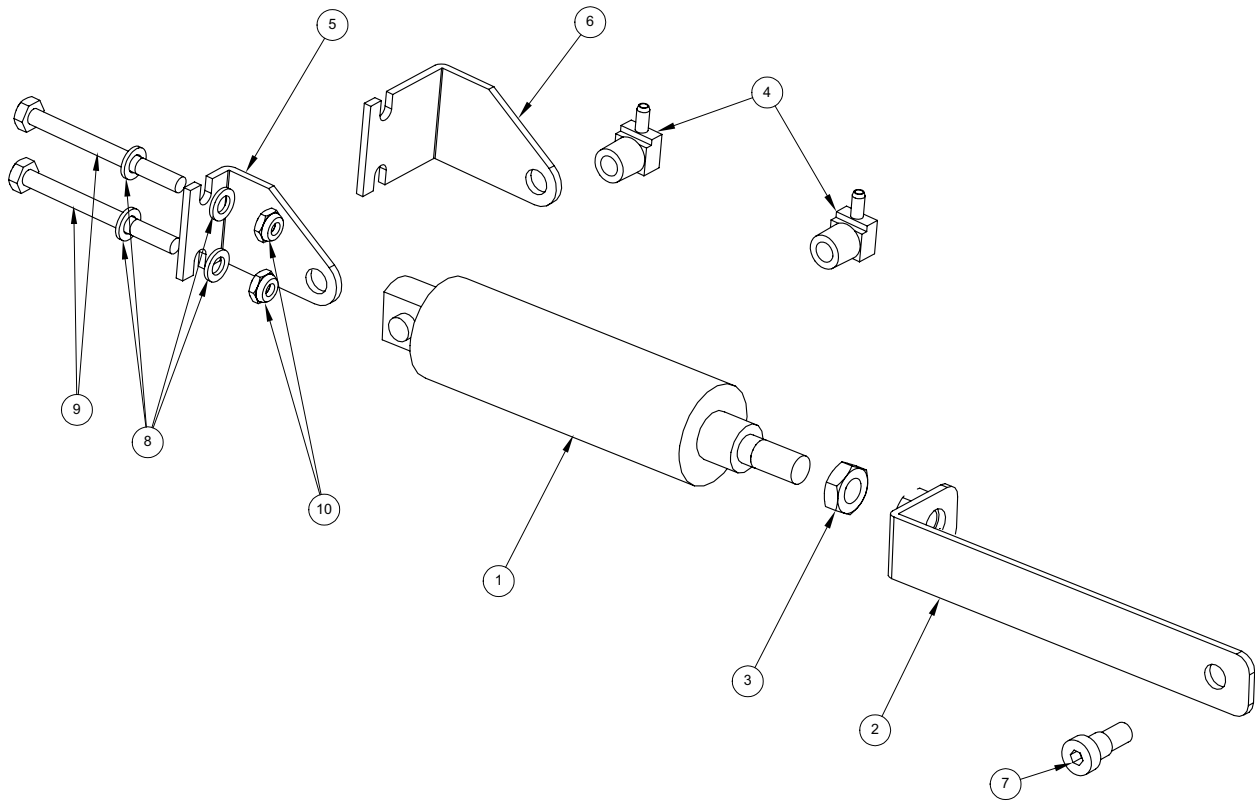

Diverter Valve Actuator Assembly Parts List

Item	Part Number	Description	Qty
1	000-169-169	Valve, Air Cylinder	1
2	000-015-926	Bracket, Air Cylinder Extension - Welded - Boxxer 427	1
3	000-094-092	Nut, 7/16"-20UNF Hex Jam	1
4	000-052-550	Elbow, 1/8" NPT x 3/16" Barb	2
5	000-015-750	Bracket, Air Cylinder Mount - Inner	1
6	000-015-748	Bracket, Air Cylinder Mount - Outer	1
7	000-143-573	Screw, 5/16-18 Shoulder, 3/8" Dia x 1/2"	1
8	000-174-003	Washer, 1/4" Flat	4
9	000-143-180	Screw, 1/4"20UNC x 2.75" Lg. Hex Head	2
10	000-094-071	Nut, 1/4"-20UNC Hex Nylock Half	2

Figure 1-16 Blower Assembly

D-5573 Rev H

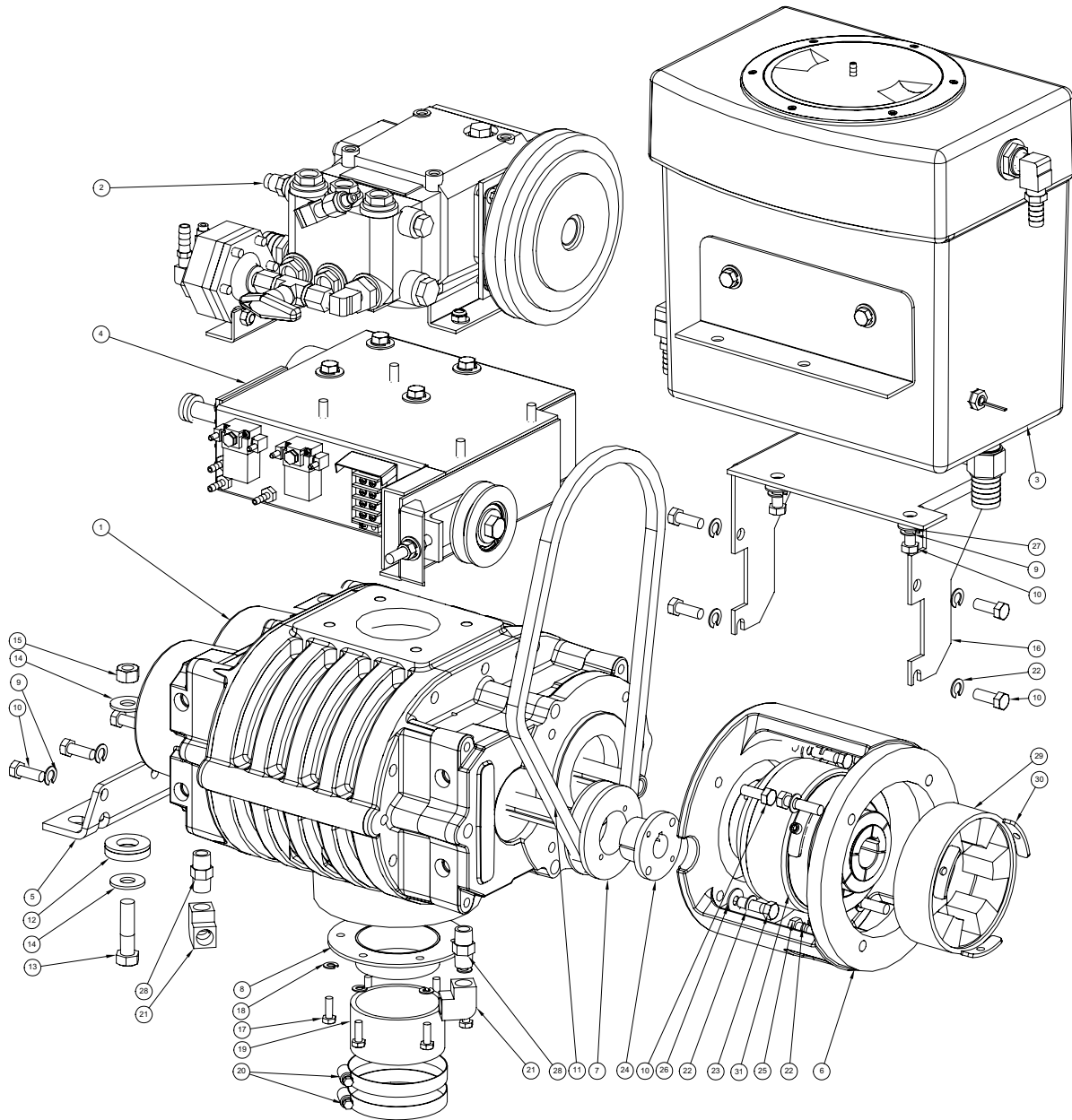

Blower Assembly Parts List

Item	Part Number	Description	Qty
1	000-111-167	Blower, MD 4007 C-Face Dual Shaft - Boxxer 427	1
2	Fig. 1-17	Assembly, Pump - Boxxer 427	1

Blower Assembly Parts List

Item	Part Number	Description	Qty
3	Fig. 1-20	Assembly, Water Box - Boxxer 427	1
4	Fig. 1-19	Assembly, Pump Mounting Bracket - Boxxer 427	1
5	000-015-814	Bracket, Dominator Mounting - Boxxer 421	1
6	000-042-061	Housing, Bell - Boxxer 427	1
7	000-109-112	Pulley, 3.50" Pump Drive	1
8	000-001-115	Adapter, Blower Flange To 3" M Slip - Boxxer 427	1
9	000-174-057	Washer, 3/8" Lock	5
10	000-143-018	Screw, 3/8"-16UNC x 1.00" Lg. Grade 8	10
11	000-010-123	Belt, EPDM 40" A-Section	1
12	000-174-105	Washer, 1-1/16" I.D. Self Aligning Spherical 2 Pc. Set	1
13	000-143-567	Screw, 1/2"-13UNC x 2.0" Lg. Hex HD Grd 8 Bo	1
14	000-174-007	Washer, 1/2" Flat	2
15	000-094-037	Nut, 1/2"-13UNC Hex 2-Way Locking - Z/P	1
16	000-015-897	Bracket, Water Box Support	1
17	000-143-001	Screw, 1/4"-20UNC x 0.75" Lg. Hex Head	6
18	000-174-019	Washer, 1/4" Lock	6
19	000-068-398	Hose, 3" I.D. x 3 Ply Silicone	1
20	000-033-013	Clamp, Size #48 Hose	2
21	000-052-142	Elbow, 3/8" FPT x FPT	2
22	000-174-021	Washer, 3/8" Lock	11
23	000-143-025	Screw, 3/8"-16UNC x 1.25" Lg. Hex Head Grd 8	3
24	000-020-019	Bushing, #H x 7/8" Bore	1
25	000-143-200	Screw, 3/8"-16UNC x 1.50" Lg. Grade 8	4
26	000-174-004	Washer, 5/16" Flat	3
27	000-174-032	Washer, 3/8" Flat	2
28	000-052-074	Nipple, 3/8" NPT Hex	2
29	000-152-010	Sleeve, 50 Series Split (Replacement)	1
30	000-078-424	Kit, Metal Ring Retainer 3 Pc. (Replacement)	1
31	000-039-053	Coupler, 50 Series	1

Figure 1-17 Pump Assembly
D-5574 Rev D

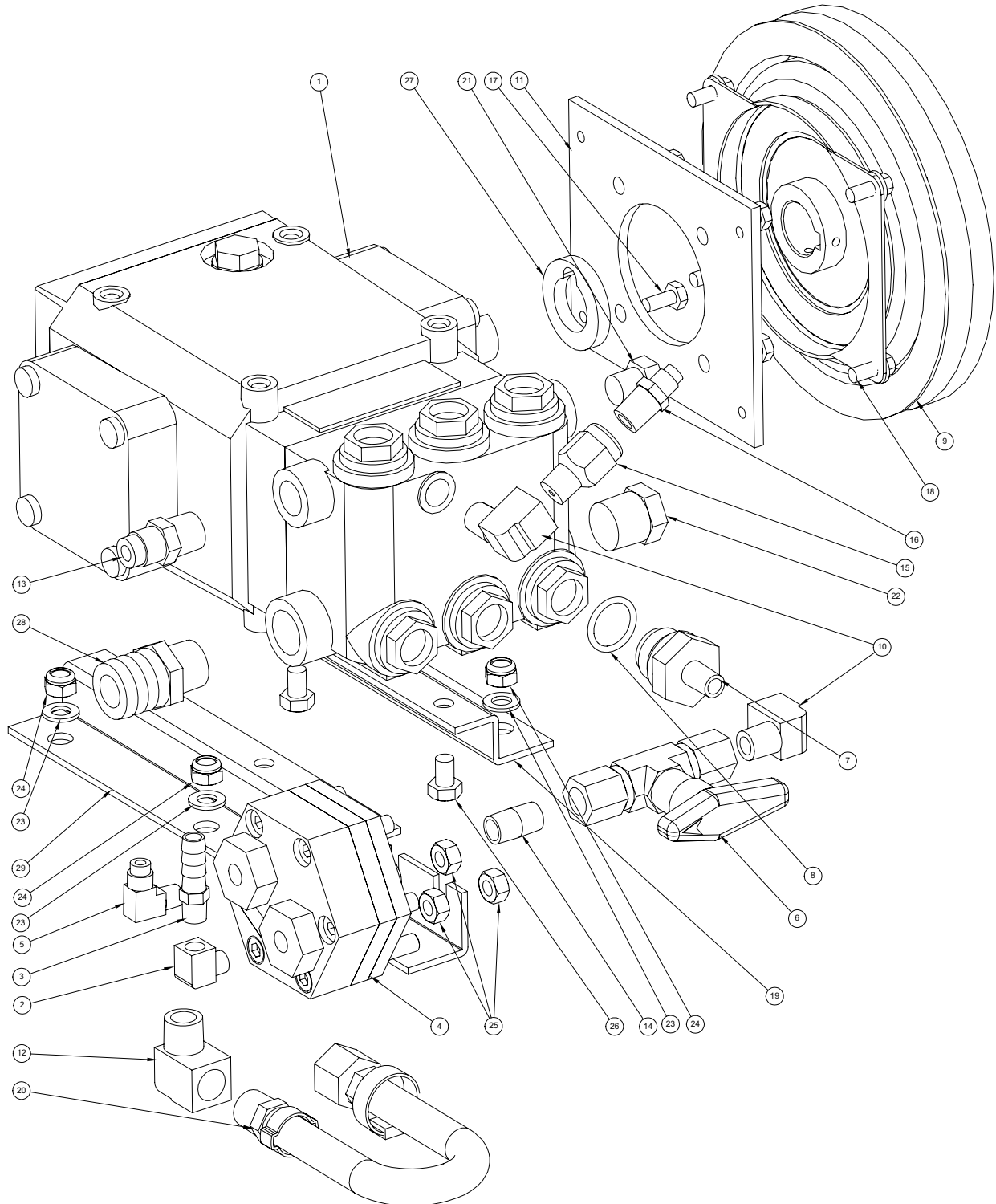

Pump Assembly Parts List

Item	Part Number	Description	Qty
1	000-111-041	Pump, Hydra Pump V - Boxxer 427	1
2	000-052-084	Elbow, 1/8" NPT Street	1
3	000-052-099	Insert, #26 (1/8" NPT x 3/8" Barb)	1
4	Fig. 1-18	Assembly, Chemical Pump - Boxxer 427	1
5	000-052-531	Elbow, 1/8" NPT x 1/4" SAE	1
6	000-169-176	Valve, 2 Way Chemical Pump	1
7	000-001-096	Adapter, Chemical Pump To Comet Pump	1
8	000-097-057	O-Ring, Adapter - Chemical Pump	1
9	000-036-008	Clutch, Electric Pump	1
10	000-052-085	Elbow, 1/4" NPT Street	2
11	000-105-312	Plate, Clutch Mount - Hydra Pump V - Boxxer 427	1
12	000-052-086	Elbow, 3/8" NPT Street	1
13	000-052-128	Nipple, 3/8" NPT x 3/8" Male Propane	1
14	000-052-517	Nipple, 1/4" NPT Close	1
15	000-135-052	Regulator, Hi PSI Snubber	1
16	000-052-527	Nipple, 1/4" SAE x 1/4" NPT	1
17	000-143-221	Screw, M6-1 x 14mm Lg. Hex Head	4
18	000-143-141	Screw, 1/4"-20UNC x 1/2" Lg. Whiz Lock	4
19	000-114-017	Rail, HydraPump V Mounting - Boxxer 427	1
20	000-068-219	Hose, Spitfire Pump Drain	1
21	000-106-003	Plug, 3/8" NPT Hex	1
22	000-106-004	Plug, 1/2" NPT Hex	1
23	000-174-049	Washer, 5/16" Flat	4
24	000-094-038	Nut, 5/16"-18UNC Nylock	4
25	000-094-013	Nut, 5/16"-24UNF Hex	4
26	- - -	Screw, 8mm x 1.0 x 12mm Lg.	4
27	000-154-145	Spacer, Comet Pump Clutch - Boxxer 427	1
28	000-052-753	Insert, #816 (1/2" NPT x 1" Barb)	1
29	000-114-019	Rail, HydraPump V / Chem Pump Mounting - Boxxer 427	1

Figure 1-18 Chemical Pump Assembly
C-6555 Rev A

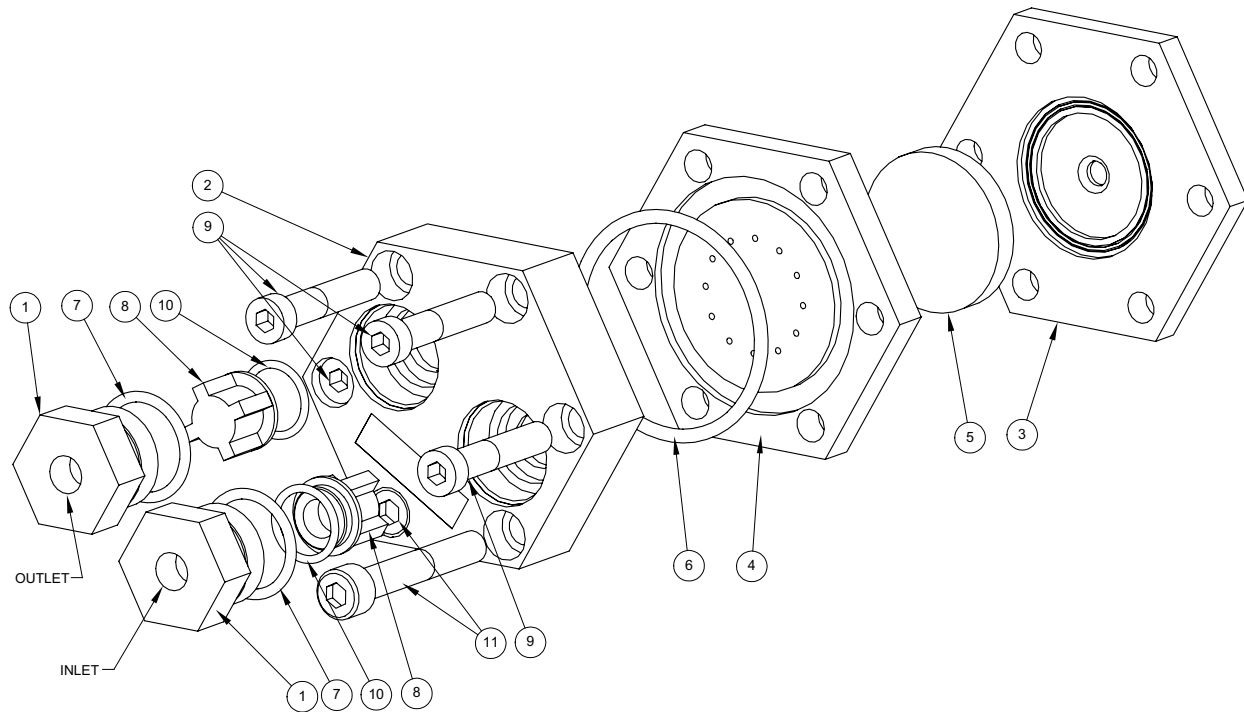

Chemical Pump Assembly Parts List

Item	Part Number	Description	Qty
1	000-106-110	Plug, Check Valve - Chemical Pump	2
2	000-064-015	Cover, Chemical Pump	1
3	000-111-030	Body, Chemical Pump	1
4	000-105-071	Mid Plate, Chemical Pump	1
5	000-046-010	Diaphragm, Chemical Pump	1
6	000-097-055	O-Ring, Chemical Pump Midplate An Size -227 Viton	1
7	000-097-056	O-Ring, Check Valve Plug - Chemical Pump	2
8	000-169-155	Valve, Check, - Last Step Chemical Injection	2
9	000-143-152	Screw, 5/16"-24UNF x 1.50" Lg. Socket Head	4
10	000-097-054	O-Ring, Chem. Pump Valve Viton-Parker 2-114	2
11	000-143-574	Screw, 5/16"-24UNF x 2" Lg. Soc. Head Grade L9	2

Figure 1-19 Pump Mounting Bracket Assembly
D-5766 Rev F

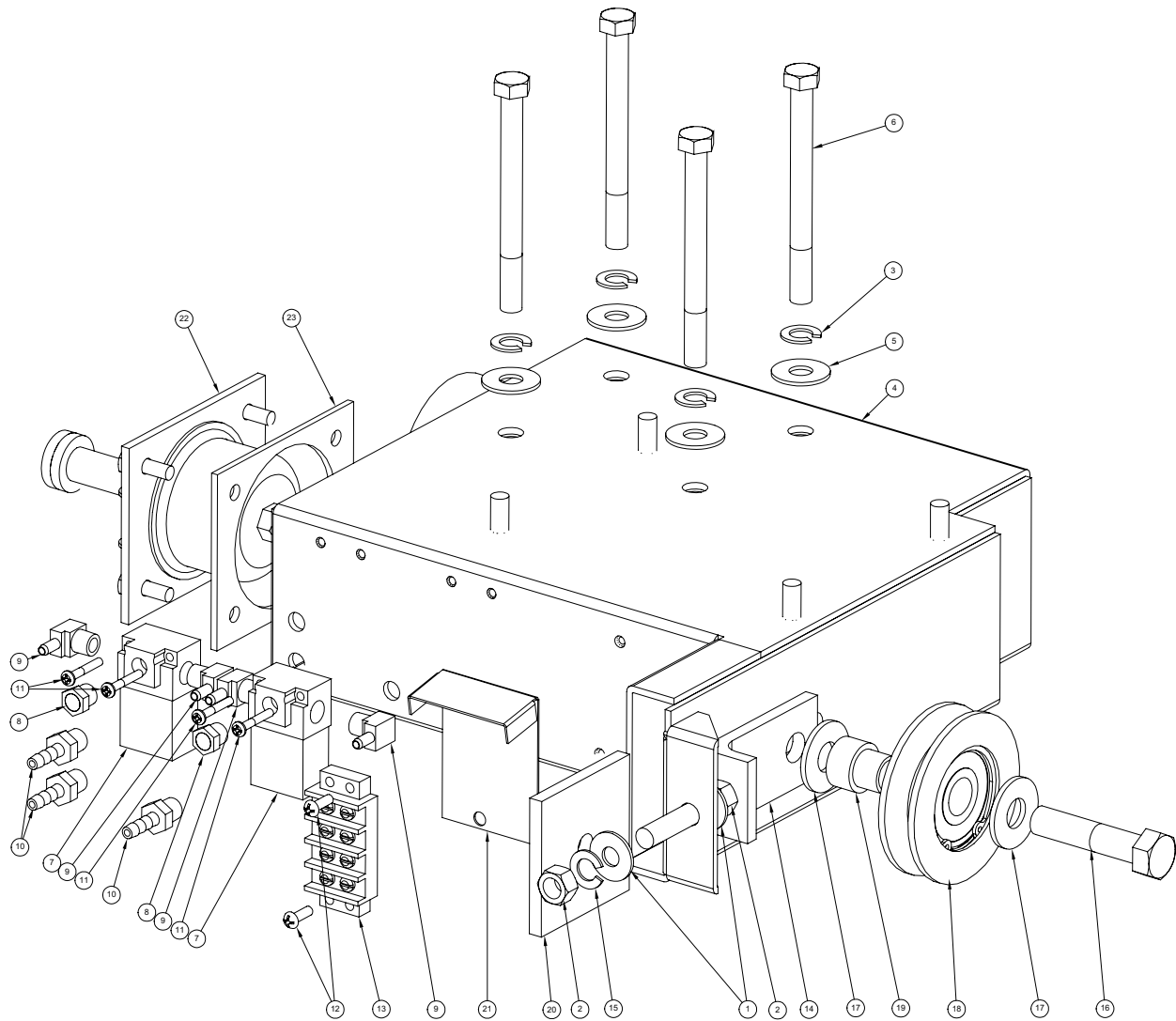

Pump Mounting Bracket Assembly Parts List

Item	Part Number	Description	Qty
1	000-174-032	Washer, 3/8" Flat	2
2	000-094-014	Nut, 3/8"-16UNC Hex Zinc Plated	2
3	000-174-021	Washer, 3/8" Lock	4
4	000-015-893	Bracket, Pump Mounting - Welded	1
5	000-174-005	Washer, 3/8" Flat	4
6	000-143-139	Screw, 3/8"-16UNC x 4.00 Lg. Grd 8	4
7	000-169-070	Valve, Primary Vac. Solenoid	2
8	000-106-014	Plug, Gearbox Vent	2
9	000-052-106	Insert, 1/8" NPT x 5/32" Barb x 90°	4
10	000-052-293	Insert, #23 (1/8" NPT x 3/16" Barb)	3
11	000-143-047	Screw, #6-32UNC x 7/8" Lg. Pan Head Phillips	4
12	000-143-050	Screw, #8-32UNC x 0.50" Lg. Round Head Phillips	2
13	000-012-001	Block, 4 Lead Electrical Terminal	1
14	000-015-746	Bracket, Pump Idler - Boxxer 421	1
15	000-174-057	Washer, 3/8" Lock	1
16	000-143-041	Screw, 1/2"-13UNC x 2.25" Lg. Hex Head	1
17	000-174-012	Washer, 1/2" SAE H/D Flat	2
18	000-109-093	Pulley, 3" "A" Sect. Ball Bearing - Assembled	1
19	000-154-049	Spacer, Pump Idler Mounting - Boxxer 421	1
20	000-105-207	Plate, Pump Idler Nut - Boxxer 421	1
21	000-108-145	Protector, Drip - Wire Terminal	1
22	Fig. 1-38	Assembly, Vacuum Relief Valve (Collector Box)	1
23	000-057-207	Gasket, Vacuum Relief Valve Plate	1

Figure 1-20 Water Box Assembly
D-5575 Rev H

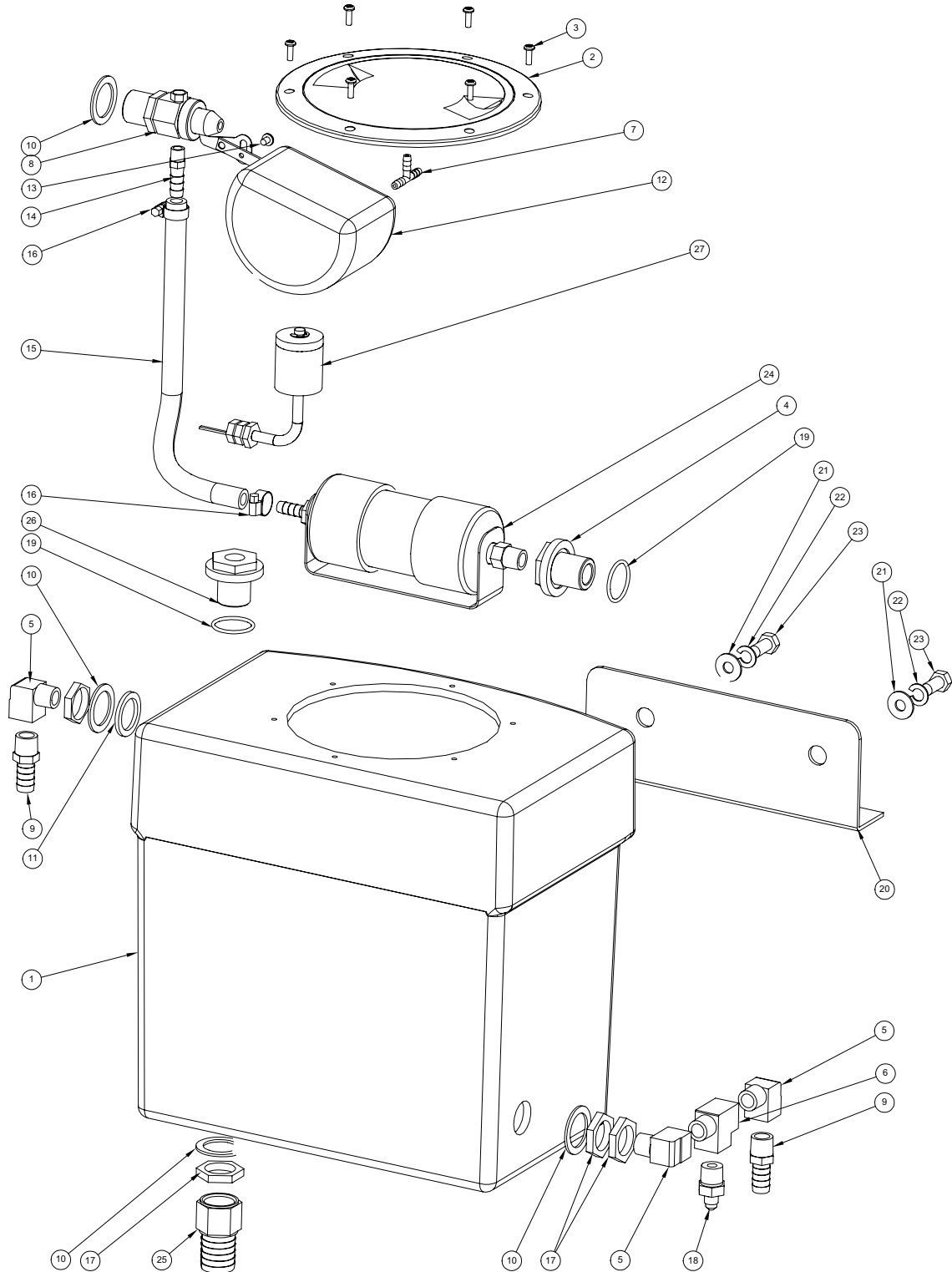

Water Box Assembly Parts List

Item	Part Number	Description	Qty
1	000-159-107	Tank, Poly Water Box - Modified	1
2	000-041-005	Cover, 6"	1
3	000-143-314	Screw, #8 x 1/2" Lg. Pan Head	6
4	000-052-660	Bulkhead, 3/8" FPT x 3/8" FPT	1
5	000-052-086	Elbow, 3/8" NPT Street	3
6	000-052-023	Tee, 3/8" NPT Male Street	1
7	000-052-155	Tee, 3/16" Plastic Vacuum Insert	1
8	000-169-167	Valve, Mechanical Incoming Water - Water Box	1
9	000-052-105	Insert, #68 (3/8" NPT x 1/2" Barb)	2
10	000-174-063	Washer, 1.5" O.D. x 1.073" I.D. x 0.075" Thk.	4
11	000-057-052	Gasket, 1" Garden Hose	1
12	000-005-007	Float, Water Box	1
13	000-143-336	Screw, #10-32UNF x 0.25" Lg. Pan Head Phillips	1
14	000-052-099	Insert, #26 (1/8" NPT x 3/8" Barb)	1
15	000-068-326	Hose, 3/8" I.D. Clear w/ Braid Solution	1
16	000-033-005	Clamp, Size #5 Hose	2
17	000-094-097	Nut, 1-14" Brass Water Box	3
18	000-052-662	Nipple, 3/8" NPT x 1/4" M SAE	1
19	000-097-041	O-Ring, 1/2" Bulkhead	2
20	000-015-896	Mount, Water Box - Boxxer 427	1
21	000-174-032	Washer, 3/8" Flat	2
22	000-174-057	Washer, 3/8" Lock	2
23	000-143-017	Screw, 3/8"-16UNC x 0.75" Lg. Hex Head Grd. 8	2
24	000-049-151	Assembly, Diffuser Filter - Boxxer 427 (Fig. 1-41)	1
25	000-050-754	Insert, #F816 (1/2" FPT x 1" Barb)	1
26	000-052-728	Bulkhead, 1/2" FPT x 3/8" FPT	1
27	000-157-0801	Assembly, Float Switch w/ Polyprop. Barrel (Fig. 1-42)	1

Figure 1-21 Dash Upper Assembly - Front View
D-5576 Rev A

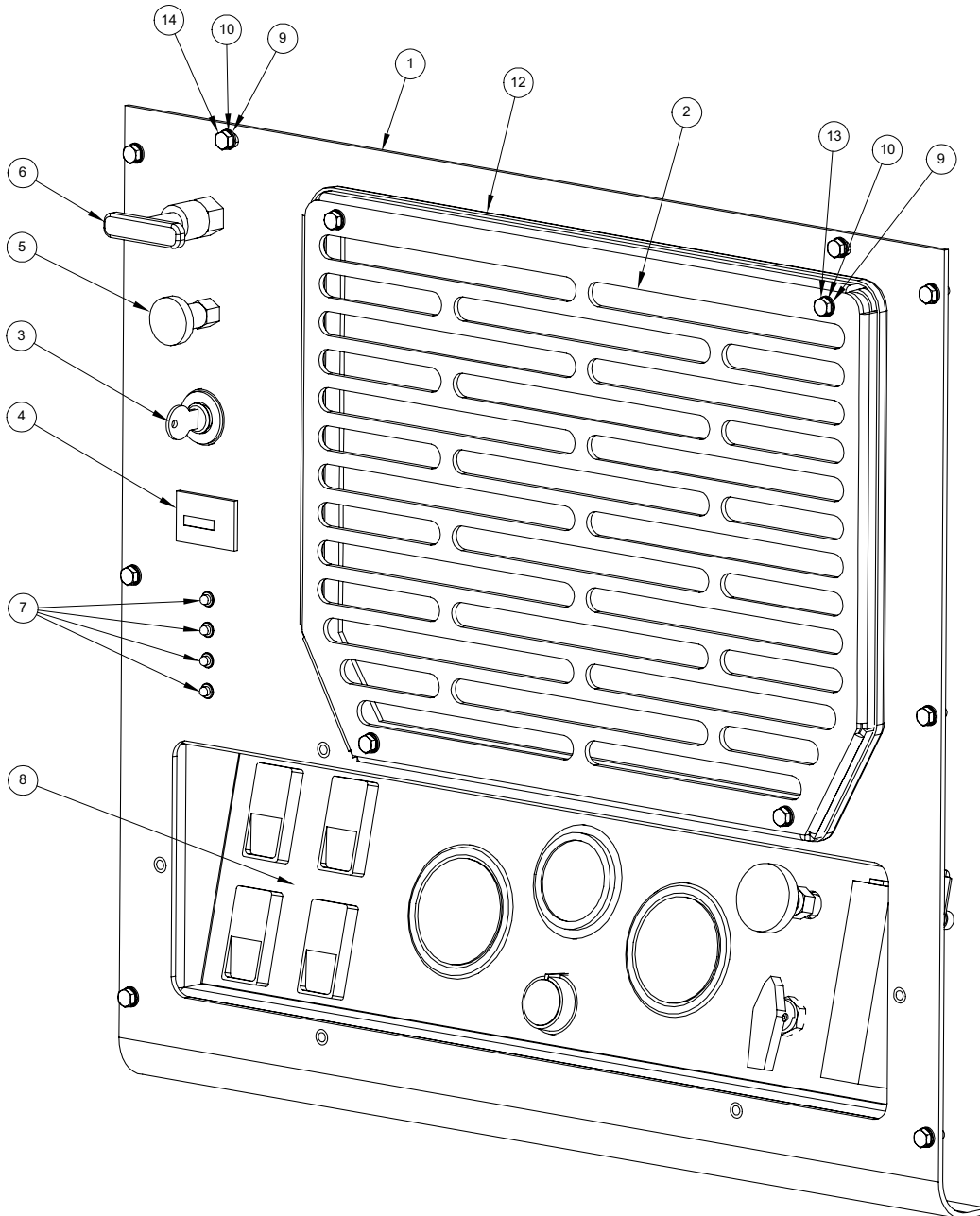
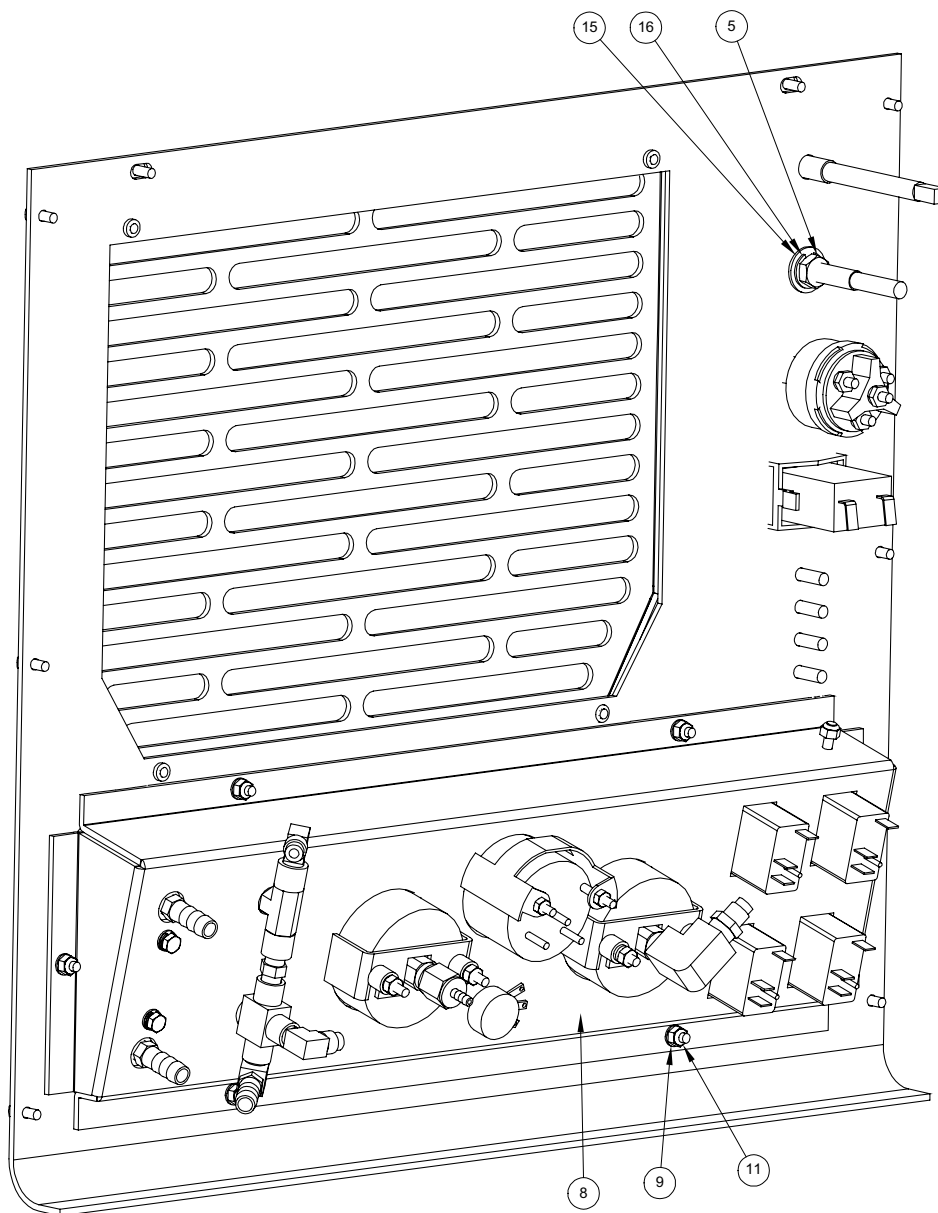

Figure 1-22 Dash Upper Assembly - Rear View
D-5576 Rev A



Dash Upper Assembly Parts List

Item	Part Number	Description	Qty
1	000-100-141	Panel, Upper Dash - Boxxer 427	1
2	000-100-145	Panel, Grill - Boxxer 427	1
3	000-157-008	Switch, Ignition	1
4	000-074-018	Meter, Rectangular w/o Bezel	1
5	000-025-002	Cable, Choke (3 Foot)	1
6	000-025-020	Cable, Throttle Kohler	1
7	000-084-011	Light, Red Led Indicator Mini	4
8	610-020-033	Assembly, Dash Guage Panel - Boxxer 427 (Fig. 1-23)	1
9	000-174-001	Washer, #10 Flat	18
10	000-174-014	Washer, #10 Lock	12
11	000-094-034	Nut, #10-24UNC Nylock	6
12	000-131-131	Trimlock, 3/8" x 1/8" Groove	1
13	000-143-134	Screw, #10-24UNC x 1.00" Lg Hex Head	4
14	000-143-126	Screw, #10-24UNC x 0.50" Lg. Hex Head	8
15	000-174-032	Washer, 3/8" Flat	1
16	000-174-057	Washer, 3/8" Lock	1

Figure 1-23 Dash Guage Panel Assembly
D-5585 Rev C

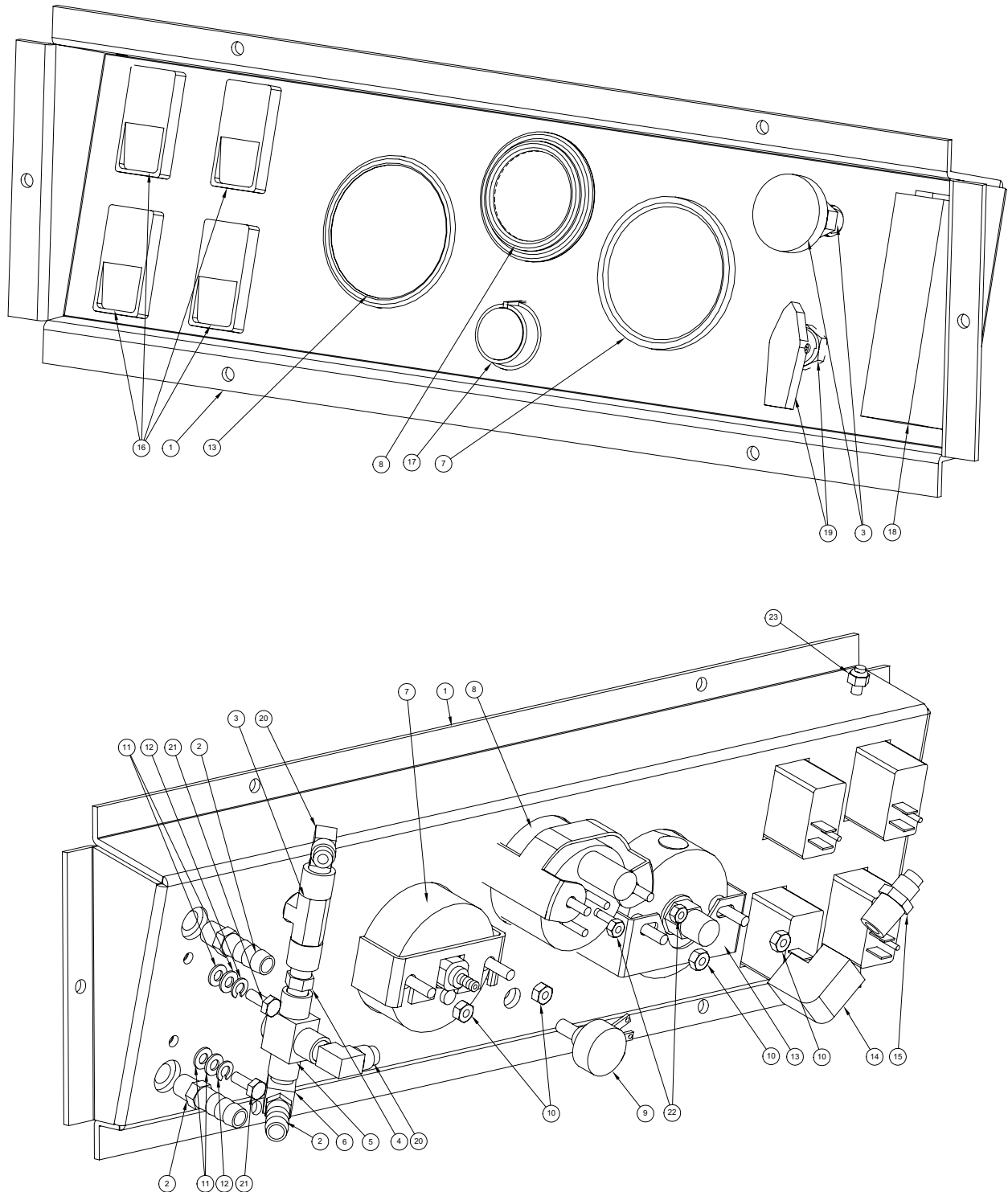

Dash Guage Panel Assembly Parts List

Item	Part Number	Description	Qty
1	000-100-150	Panel, Dash Gauge - Boxxer 427	1
2	000-052-099	Insert, #26 (1/8" NPT x 3/8" Barb)	3
3	000-169-160	Valve, Chemical Metering	1
4	000-052-069	Nipple, 1/8" NPT Hex	1
5	000-169-0171	Valve, 3-Way Ball O-Ring Style	1
6	000-052-084	Elbow, 1/8" NPT Street	1
7	000-074-017	Guage, 0-30" Hg Vac. 2 1/2" Hydramaster Face	1
8	000-074-016	Gauge, Temperature	1
9	000-149-551	Thermostat, Potentiometer Dual Controller	1
10	000-094-070	Nut, 5mm Nylock	4
11	000-174-001	Washer, #10 Flat	4
12	000-174-014	Washer, #10 Lock	2
13	000-074-007	Gauge, Pressure (0-1500 Psi)	1
14	000-052-088	Elbow, 1/4" FPT x FPT	1
15	000-052-527	Nipple, 1/4" SAE x 1/4" NPT	1
16	000-157-040	Switch, 20 AMP Rocker	4
17	000-061-056	Knob, Temperature Adjustment	1
18	000-074-030	Meter, Chemical Flow Raw	1
19	000-094-098	Nut, 7/16"-24UNF - 2 Way Metering Valve	1
20	000-052-531	Elbow, 1/8" NPT x 1/4" SAE	2
21	000-143-327	Screw, #10-32UNF x 0.50" Lg. Hex Head	2
22	000-094-002	Nut, #8-32UNC Hex	2
23	000-094-034	Nut, #10-24UNC Nylock	1

Figure 1-24 Dash Lower Assembly - Front View
D-5577 Rev E

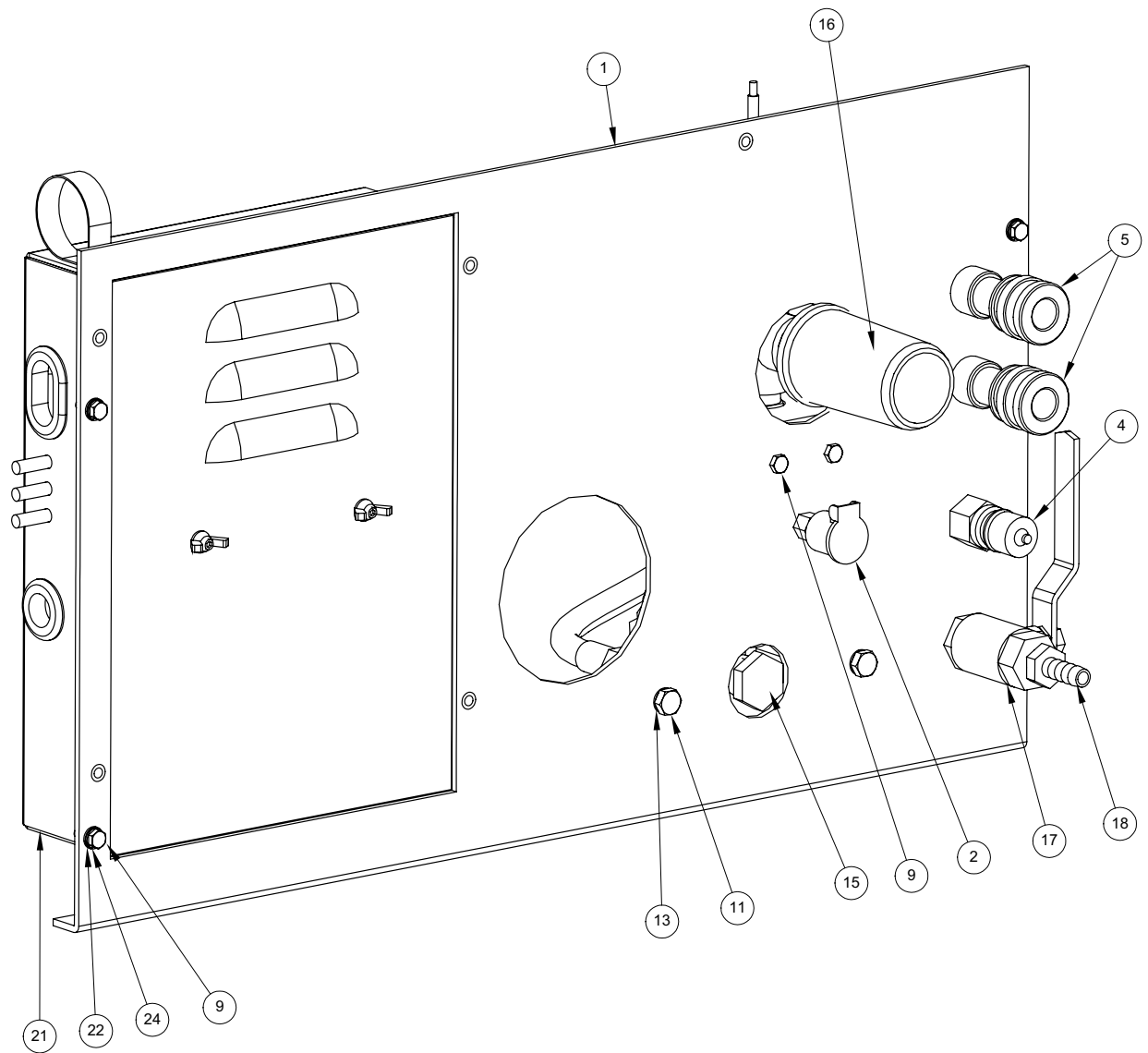
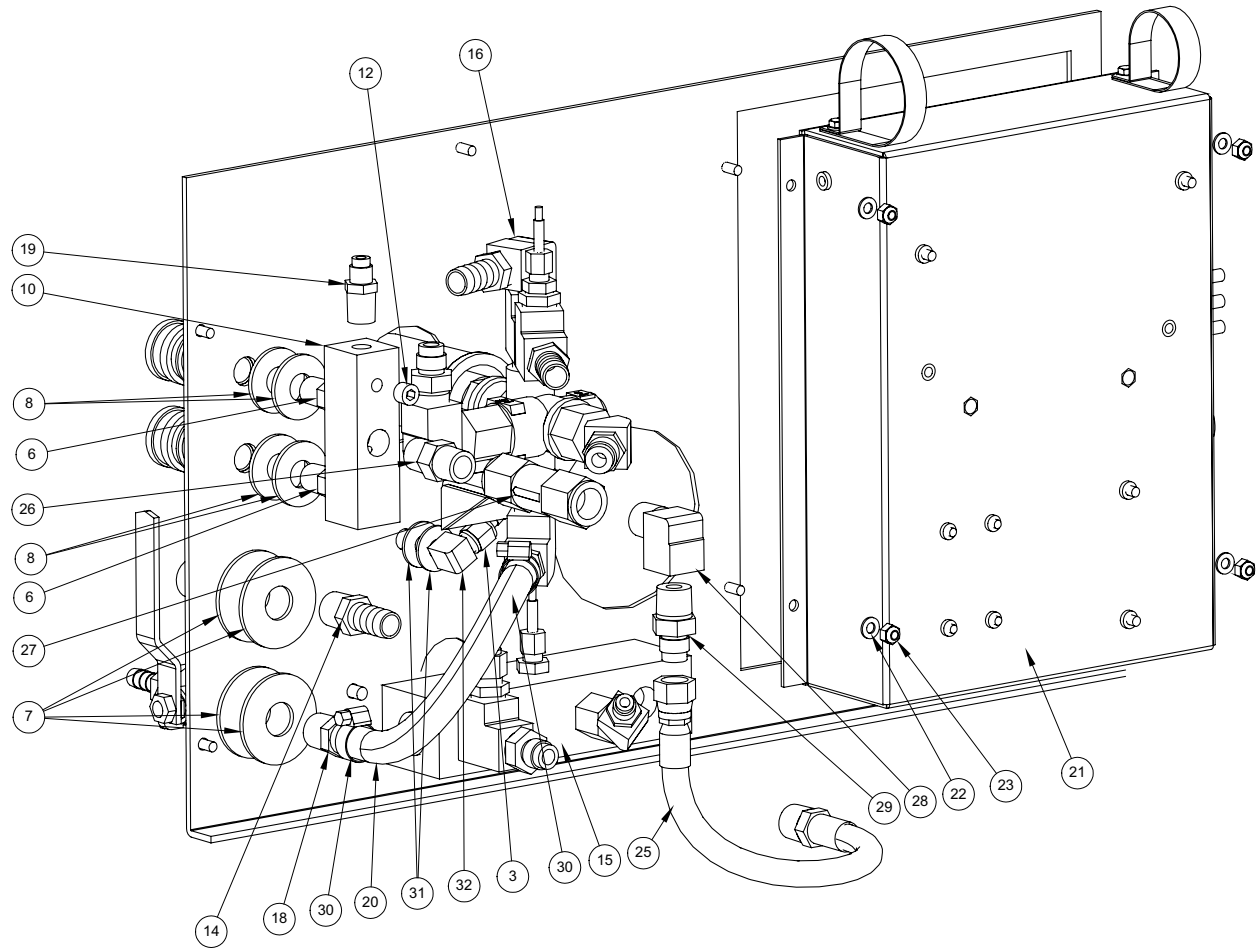

Figure 1-25 Dash Lower Assembly - Rear View
D-5577 Rev E



Dash Lower Assembly Parts List

Item	Part Number	Description	Qty
1	000-100-143	Panel, Lower Dash - Boxxer 427	1
2	000-052-272	Cup, Gravity Feed Oil Blower Lubrication Port	1

Dash Lower Assembly Parts List

Item	Part Number	Description	Qty
3	000-052-096	Insert, #F23 (1/8" FPT x 3/16" Barb)	1
4	000-052-052	Quick Connect, 660 Male w/ Viton Standard	1
5	000-052-051	Quick Connect, 440 Female w/ Epdm O-Ring	2
6	000-052-071	Nipple, 1/4" NPT Hex	2
7	000-174-008	Washer, 5/8" Flat	4
8	000-174-007	Washer, 1/2" Flat	4
9	000-143-126	Screw, #10-24UNC x 0.50" Lg. Hex Head	6
10	000-090-008	Manifold, Hi Pressure	1
11	000-143-542	Screw, 1/4"-28UNF x 0.50" Lg.	2
12	000-106-009	Plug, 1/8" NPT Allen Head	1
13	000-155-053	Spring, 1/4" Belleville Washer	2
14	000-052-105	Insert, #68 (3/8" NPT x 1/2" Barb)	1
15	Fig. 1-27	Assembly, Hi-PSI Manifold	1
16	Fig. 1-26	Assembly, By-Pass Valve	1
17	000-169-064	Valve, 3/8" NPT Full Port Ball	1
18	000-052-104	Insert, #66 (3/8" NPT x 3/8" Barb)	2
19	000-052-527	Nipple, 1/4" SAE x 1/4" NPT	1
20	000-068-017	Hose, 3/8" I.D. Bulk	1
21	610-011-033	Assembly, Electrical Control Panel - Bxr 427 (Fig. 1-28)	1
22	000-174-001	Washer, #10 Flat	8
23	000-094-034	Nut, #10-24UNC Nylock	4
24	000-174-014	Washer, #10 Lock	4
25	000-068-739	Hose, 3/8" x 16" Lg. w/ JIC & NPT Ends	1
26	000-052-074	Nipple, 3/8" NPT Hex	1
27	000-169-186	Valve, 3/8" FPT x 3/8" FPT 100 PSI Check	1
28	000-052-086	Elbow, 3/8" NPT Street	1
29	000-052-528	Nipple, 3/8" M JIC x 3/8" NPT	1
30	000-033-005	Clamp, Size #5 Hose	2
31	000-174-032	Washer, 3/8" Flat	2
32	000-052-084	Elbow, 1/8" NPT Street	1

Figure 1-26 **By-Pass Valve Assembly**
C-5581 Rev C

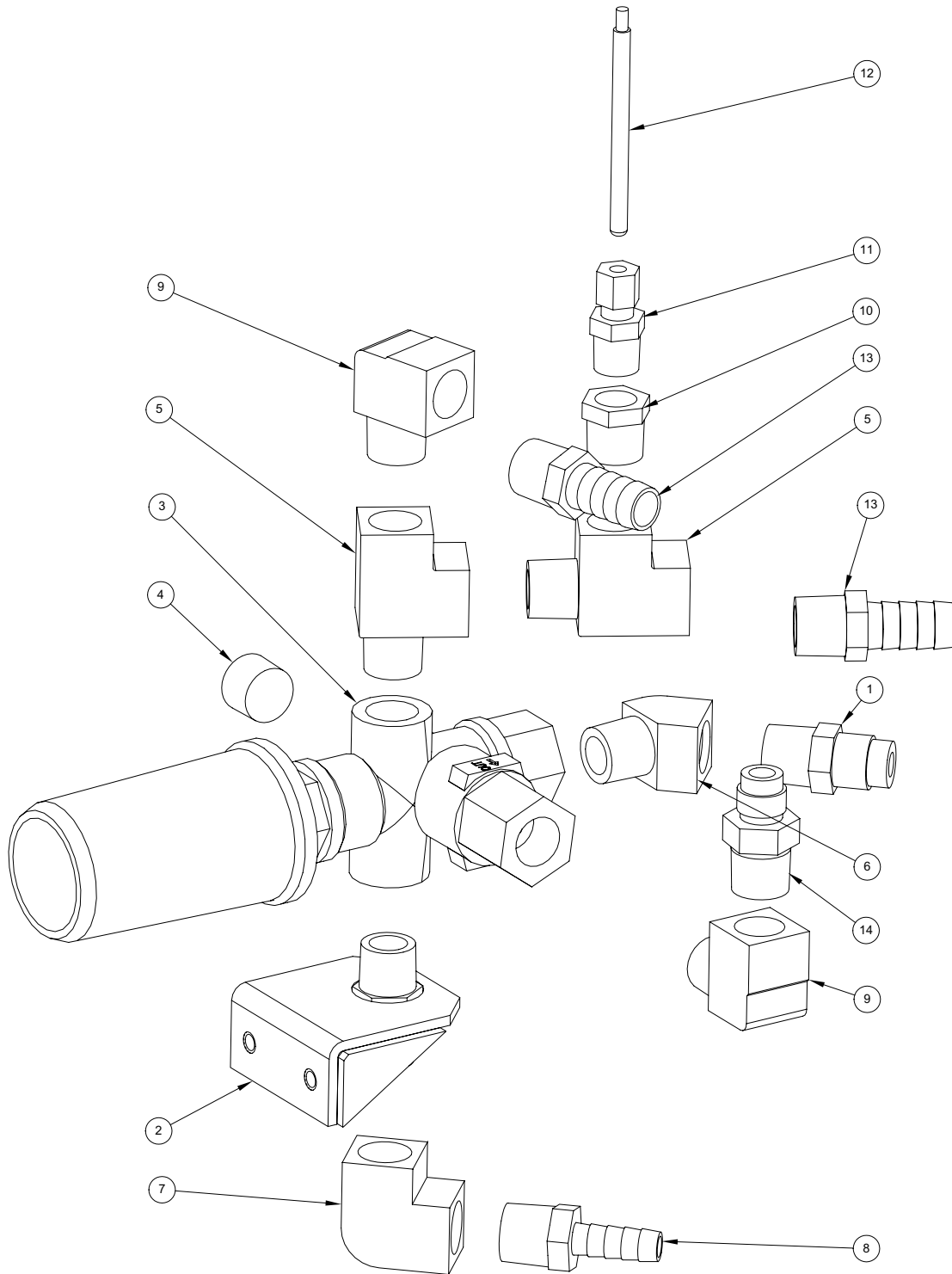

By-Pass Valve Assembly Parts List

Item	Part Number	Description	Qty
1	000-052-128	Nipple, 3/8" NPT x 3/8" Male Propane	1
2	000-015-515	Bracket, By-Pass Valve Mounting	1
3	000-169-188	Valve, PSI Regulator 0-1500 PSI - Modified	1
4	000-106-008	Plug, 3/8" NPT Allen Head	1
5	000-052-023	Tee, 3/8" NPT Male Street	2
6	000-052-083	Elbow, 3/8" NPT Street x 45°	1
7	000-052-142	Elbow, 3/8" FPT x FPT	1
8	000-052-104	Insert, #66 (3/8" NPT x 3/8" Barb)	1
9	000-052-086	Elbow, 3/8" NPT Street	2
10	000-052-061	Bushing, 3/8" NPT x 1/4" FPT	1
11	000-052-587	Compression, 3/16" x 1/4" NPT Thermocouple Fitting	1
12	000-149-540	Sensor, RTD Compression Fitting Style	1
13	000-052-105	Insert, #68 (3/8" NPT x 1/2" Barb)	2
14	000-052-528	Nipple, 3/8" M JIC x 3/8" NPT	1

Figure 1-27 Hi-PSI Manifold Assembly
C-5582 Rev A

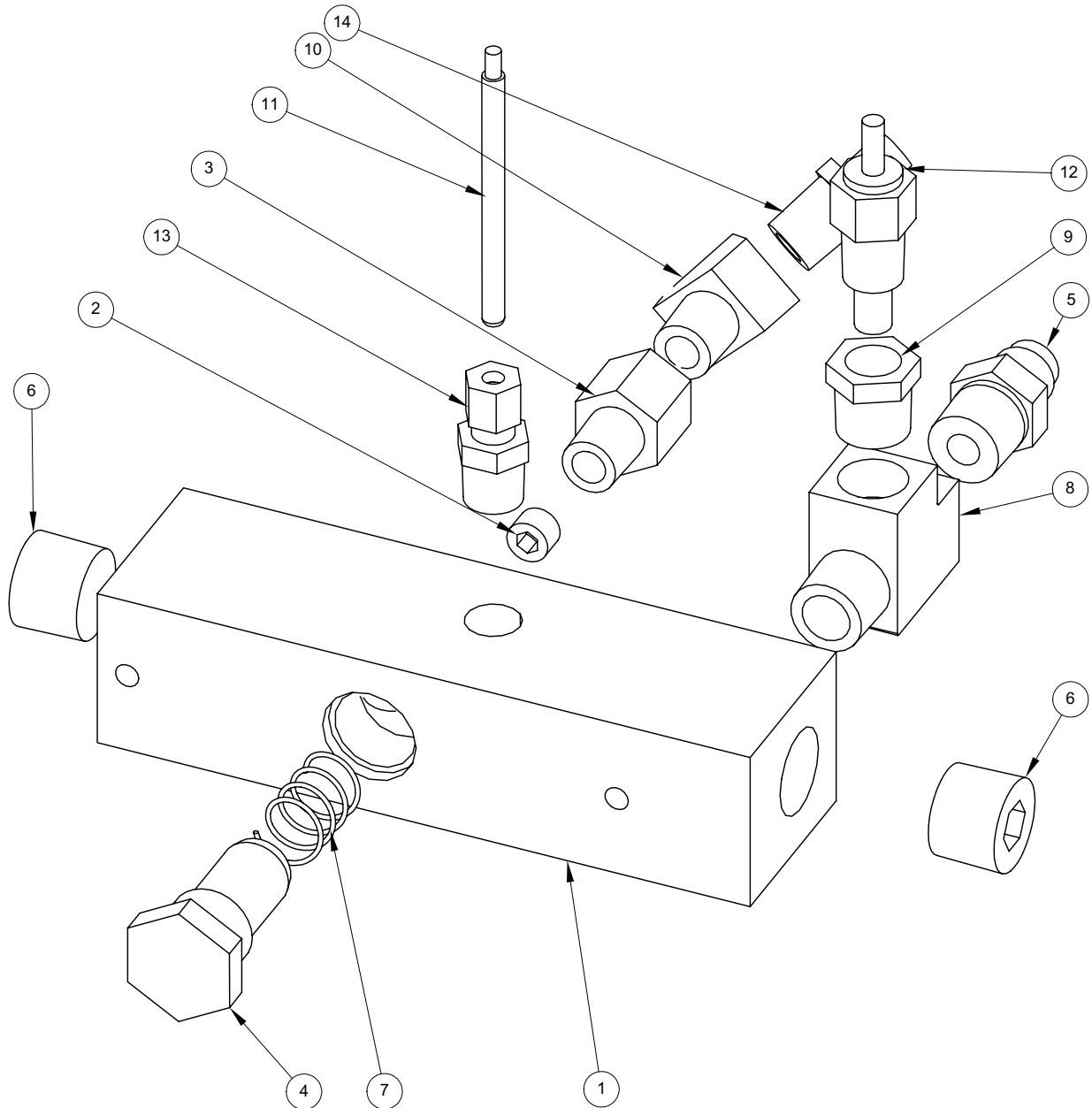

Hi-PSI Valve Assembly Parts List

Item	Part Number	Description	Qty
1	000-090-057	Manifold, Hi-PSI - Boxxer 427	1
2	000-180-004	Orifice, Set Screw 0.033"	1
3	000-052-423	Bushing, Modified Set Screw Orifice	1
4	000-049-016	Filter, 1/4" NPT Replacement "Y"	1
5	000-052-528	Nipple, 3/8" M JIC x 3/8" NPT	1
6	000-106-111	Plug, 1/2" NPT Allen	2
7	000-155-020	Spring, 0.540 O.D. x 0.041 Wire x 1.00 Lg.	1
8	000-052-023	Tee, 3/8" NPT Male Street	1
9	000-052-061	Bushing, 3/8" NPT x 1/4" FPT	1
10	000-052-082	Elbow, 1/4" NPT Street x 45°	1
11	000-149-540	Sensor, RTD Compression Fitting Style	1
12	000-149-039	Sender, Temperature	1
13	000-052-587	Compression, 3/16" x 1/4" NPT Thermocouple Fitting	1
14	000-052-527	Nipple, 1/4" SAE x 1/4" NPT	1

Figure 1-28 Electrical Control Panel Assembly
C-5583 Rev D

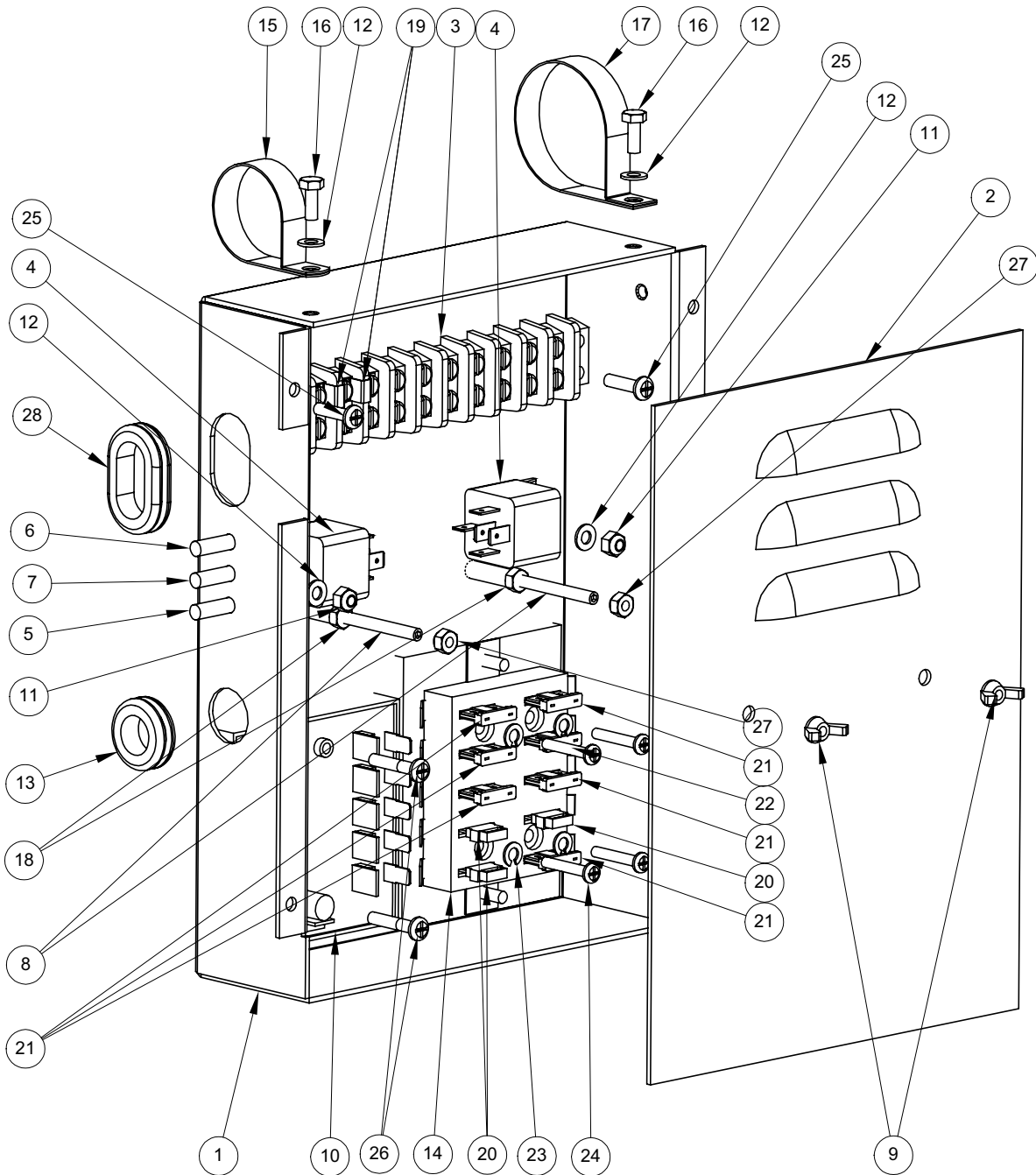

Electrical Control Panel Assembly Parts List

Item	Part Number	Description	Qty
1	000-100-137	Panel, Electrical Control - Boxxer 427	1
2	000-041-418	Cover, Electrical Control Panel - Boxxer 427	1
3	000-012-010	Block, Terminal 10 Post	1
4	000-157-022	Switch, Relay	2
5	000-084-010	Light, Green LED Indicator Mini	1
6	000-084-011	Light, Red LED Indicator Mini	1
7	000-084-012	Light, Yellow LED Indicator Mini	1
8	000-156-030	Stud, #10-32UNF x 2" Lg. Boxxer Elec. Panel Cover	2
9	000-094-108	Nut, #10-32UNF Wing	2
10	000-074-130	Controller, Temp. Dual Independent	1
11	000-094-034	Nut, #10-24UNC Nylock	2
12	000-174-001	Washer, #10 Flat	4
13	000-060-002	Grommet, Large Wiring	1
14	000-056-030	Diode Panel	1
15	000-033-053	Clamp, 1-1/2" Cushion Loop	1
16	000-143-126	Screw, #10-24UNC x 0.50" Lg. Hex Head	2
17	000-033-067	Clamp, 2" Cushion Loop	1
18	000-094-003	Nut, #10-32UNF Hex	2
19	000-037-011	Connector, "Jumper" Terminal Block	2
20	000-135-004	Diode, Plug In	3
21	000-056-007	Fuse, 10 AMP Plug In	6
22	000-056-010	Fuse, 25 AMP Plug In	1
23	000-174-014	Washer, #10 Lock	4
24	000-143-545	Screw, #8-32UNC x 1.00" Lg. Phillips Head	4
25	000-143-062	Screw, #10-24UNC x 0.75" Lg. Pan Head Phillips	2
26	000-143-534	Screw, #10-24UNC x 1.00" Lg. Pan Head Phillips	2
27	000-094-058	Nut, #10-32 UNF - Nylock	2
28	000-060-014	Grommet, 1.00" I.D. x 1.50" O.D.	1

Figure 1-29 Coolant Heat Exchanger Assembly

D-5578 Rev A

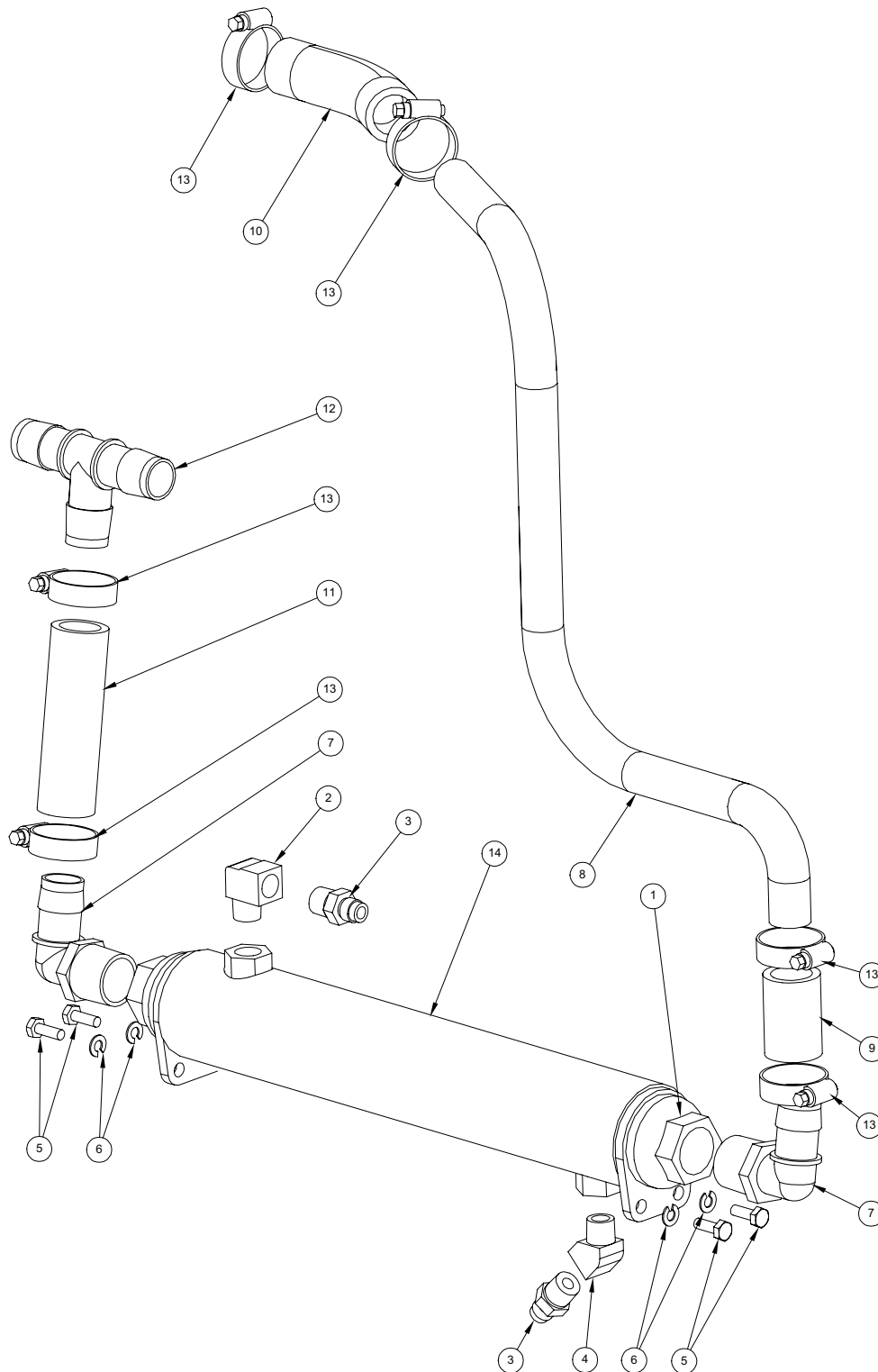

Coolant Heat Exchanger Assembly Parts List

Item	Part Number	Description	Qty
1	000-038-043	Heat Exchanger, Water To Water	1
2	000-052-086	Elbow, 3/8" NPT Street	1
3	000-052-528	Nipple, 3/8" M JIC x 3/8" NPT	2
4	000-052-083	Elbow, 3/8" NPT Street x 45°	1
5	000-143-001	Screw, 1/4"-20UNC x 0.75" Lg. Hex Head	4
6	000-174-019	Washer, 1/4" Lock	4
7	000-052-131	Elbow, 1" NPT x 1" Barb	2
8	000-125-194	Tube, Coolant Heat Exchanger To Engine - Boxxer 427	1
9	000-068-250	Hose, 1" I.D. Green Stripe	1
10	000-068-250	Hose, 1" I.D. Green Stripe	1
11	000-068-250	Hose, 1" I.D. Green Stripe	1
12	000-052-648	Tee, 1" Barb x 1" Barb x 1" Barb	1
13	000-033-020	Clamp, Size #16 Hose	6
14	000-108-134	Protector, Coolant Hx Grey Silicone Blanket	1

Figure 1-30 Blower Heat Exchanger Assembly
D-5579 Rev B

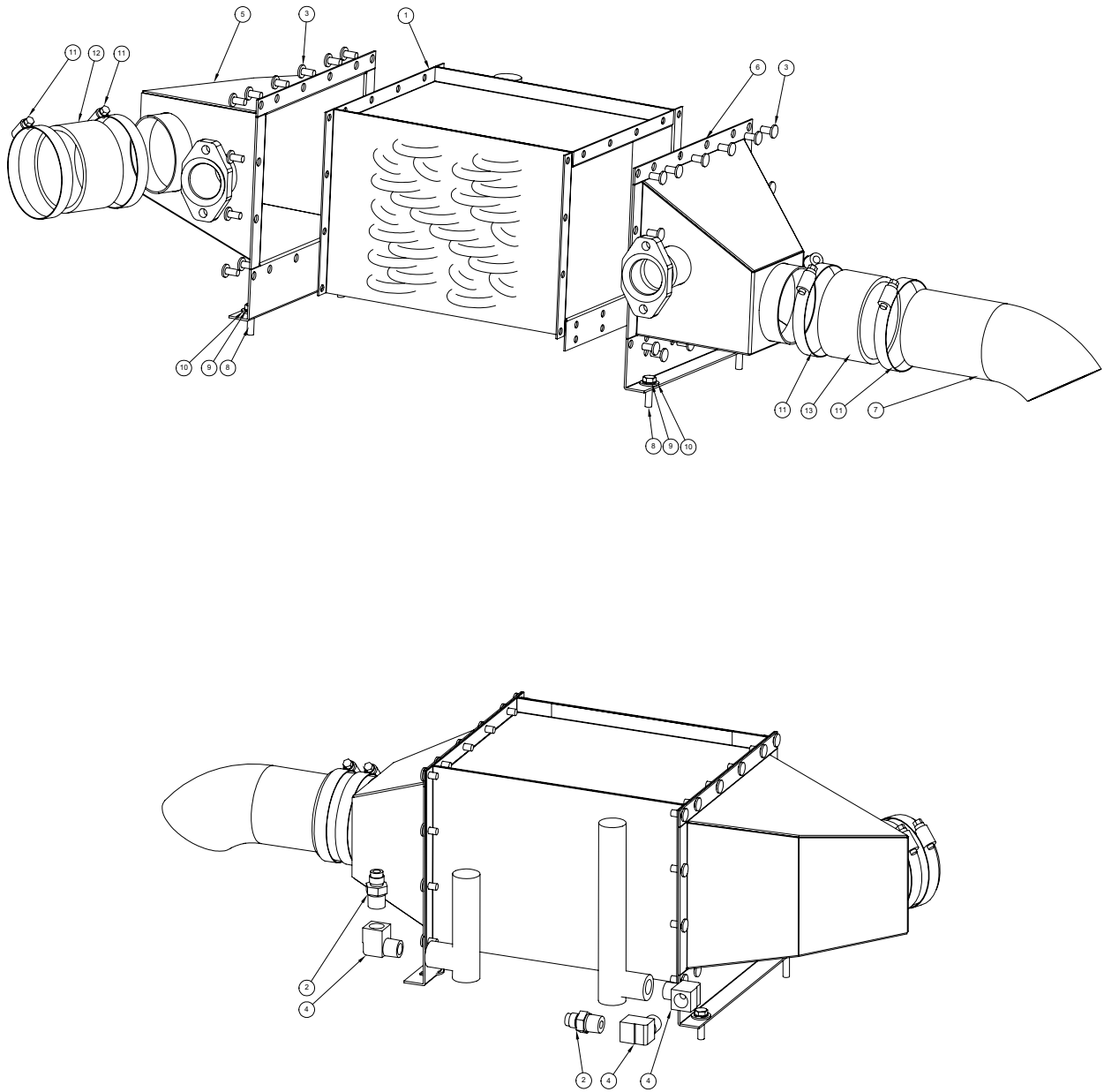

Blower Heat Exchanger Assembly Parts List

Item	Part Number	Description	Qty
1	000-038-055	Core, Blower Heat Exchanger - Boxxer 427	1
2	000-052-528	Nipple, 3/8" M JIC x 3/8" NPT	2
3	000-140-021	Rivet, 1/4" Blind x 0.50" Lg.	32
4	000-052-086	Elbow, 3/8" NPT Street	3
5	000-013-059	Box, Inlet Plenum - Welded - Boxxer 427	1
6	000-013-060	Box, Outlet Plenum - Weldment - Boxxer 427	1
7	000-001-097	Adpater, Exhaust Turndown - Raw	1
8	000-143-002	Screw, 1/4"-20UNC x 1.00" Lg. Hex Head	4
9	000-174-019	Washer, 1/4" Lock	4
10	000-174-002	Washer, 1/4" Flat	4
11	000-033-013	Clamp, Size #48 Hose	4
12	000-068-398	Hose, 3" I.D. x 3 Ply Sil.	1
13	000-068-398	Hose, 3" I.D. x 3 Ply Sil.	1

Figure 1-31 Top Cover Assembly

D-5586 Rev A

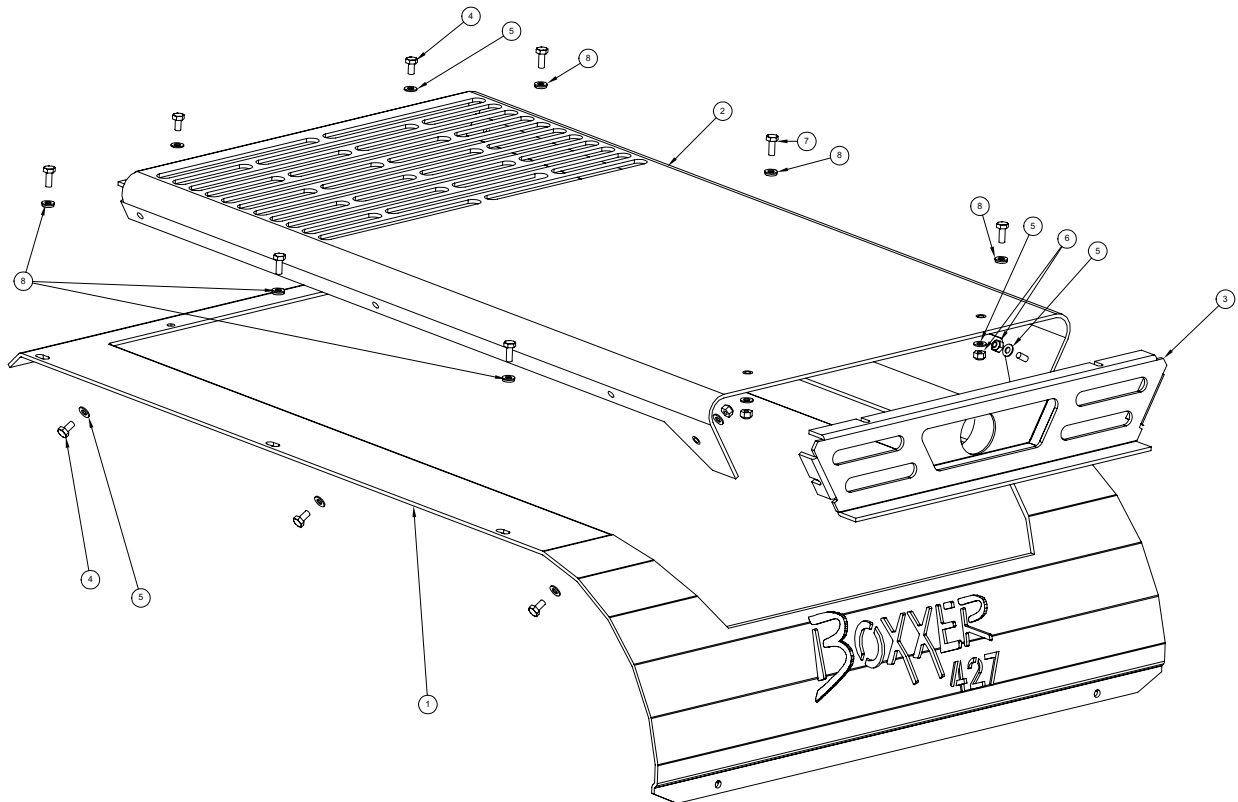

Top Cover Assembly Parts List

Item	Part Number	Description	Qty
1	000-041-416	Cover, Top Machine - Boxxer 427	1
2	000-041-422	Cover, Brow - Boxxer 427	1
3	000-100-153	Panel, Brow End - Weldment - Boxxer 427	1
4	000-143-166	Screw, #10-24UNC x 0.38" Lg. Hex Head	8
5	000-174-001	Washer, #10 Flat	12
6	000-094-034	Nut, #10-24UNC Nylock	4
7	000-143-126	Screw, #10-24UNC x 0.50" Lg. Hex Head	6
8	000-174-036	Washer, #10 Flat Rubber Backed	6

Figure 1-32 Machine Right Side Cover Assembly
D-5762 Rev -

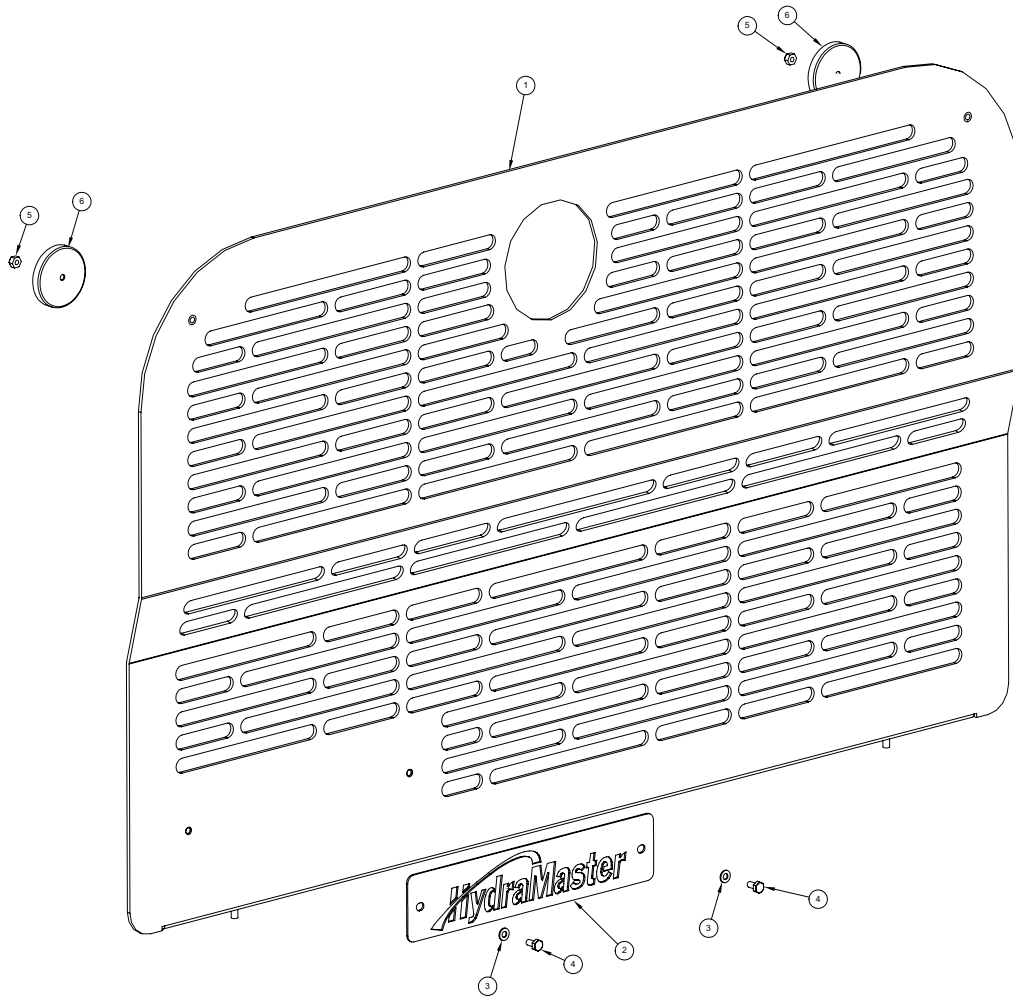

Machine Right Side Cover Assembly Parts List

Item	Part Number	Description	Qty
1	000-041-419	Cover, Right Side Machine - Boxxer 427	1
2	000-105-313	Plate, Hydramaster Name- Roto Tank	1
3	000-174-001	Washer, #10 Flat	2
4	000-143-166	Screw, #10-24UNC x 0.38" Lg. Hex Head	2
5	000-094-034	Nut, #10-24UNC Nylock	2
6	000-089-003	Magnet, Treadmaster	2

Figure 1-33 Machine Left Side Cover Assembly
D-5587 Rev -

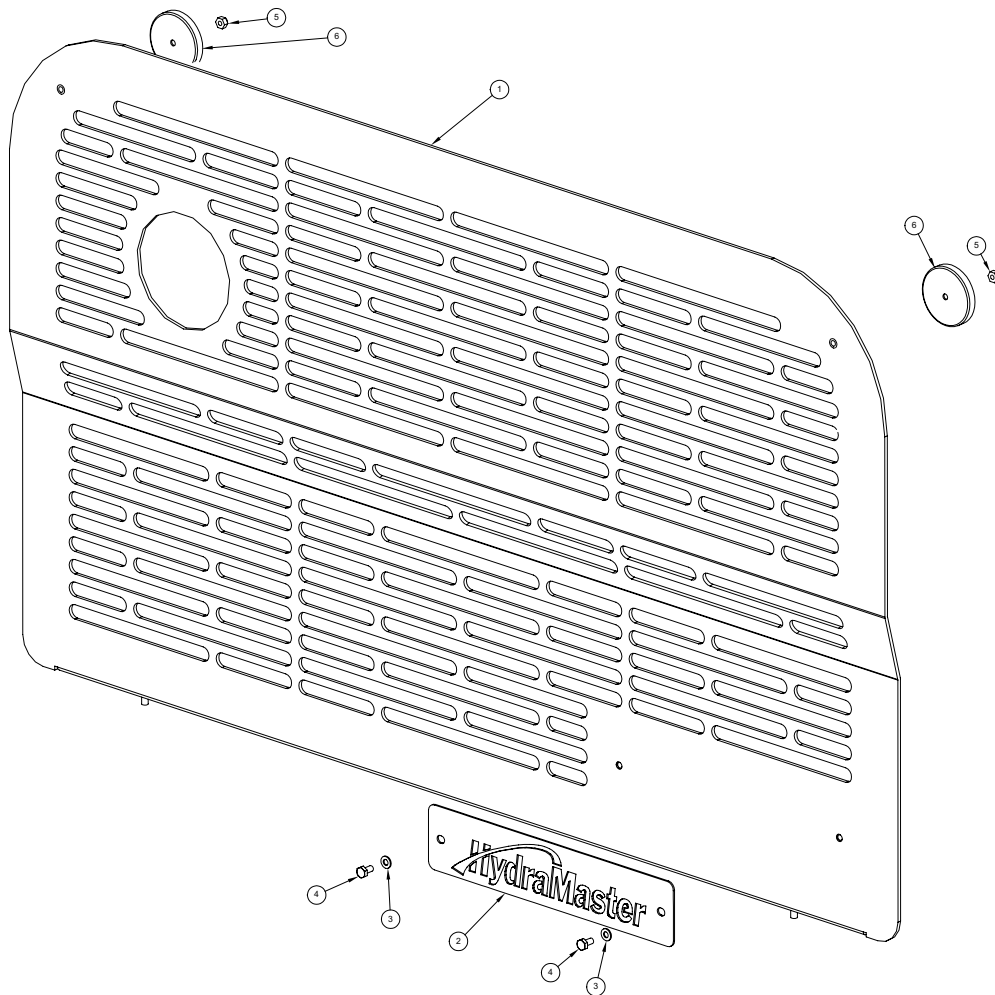

Machine Left Side Cover Assembly Parts List

Item	Part Number	Description	Qty
1	000-041-417	Cover, Left Side Machine - Boxxer 427	1
2	000-105-313	Plate, Hydramaster Name- Roto Tank	1
3	000-174-001	Washer, #10 Flat	2
4	000-143-166	Screw, #10-24UNC x 0.38" Lg. Hex Head	2
5	000-094-034	Nut, #10-24UNC Nylock	2
6	000-089-003	Magnet, Treadmaster	2

Figure 1-34 70 Gallon Universal Recovery Tank Assembly
D-6860 Rev B

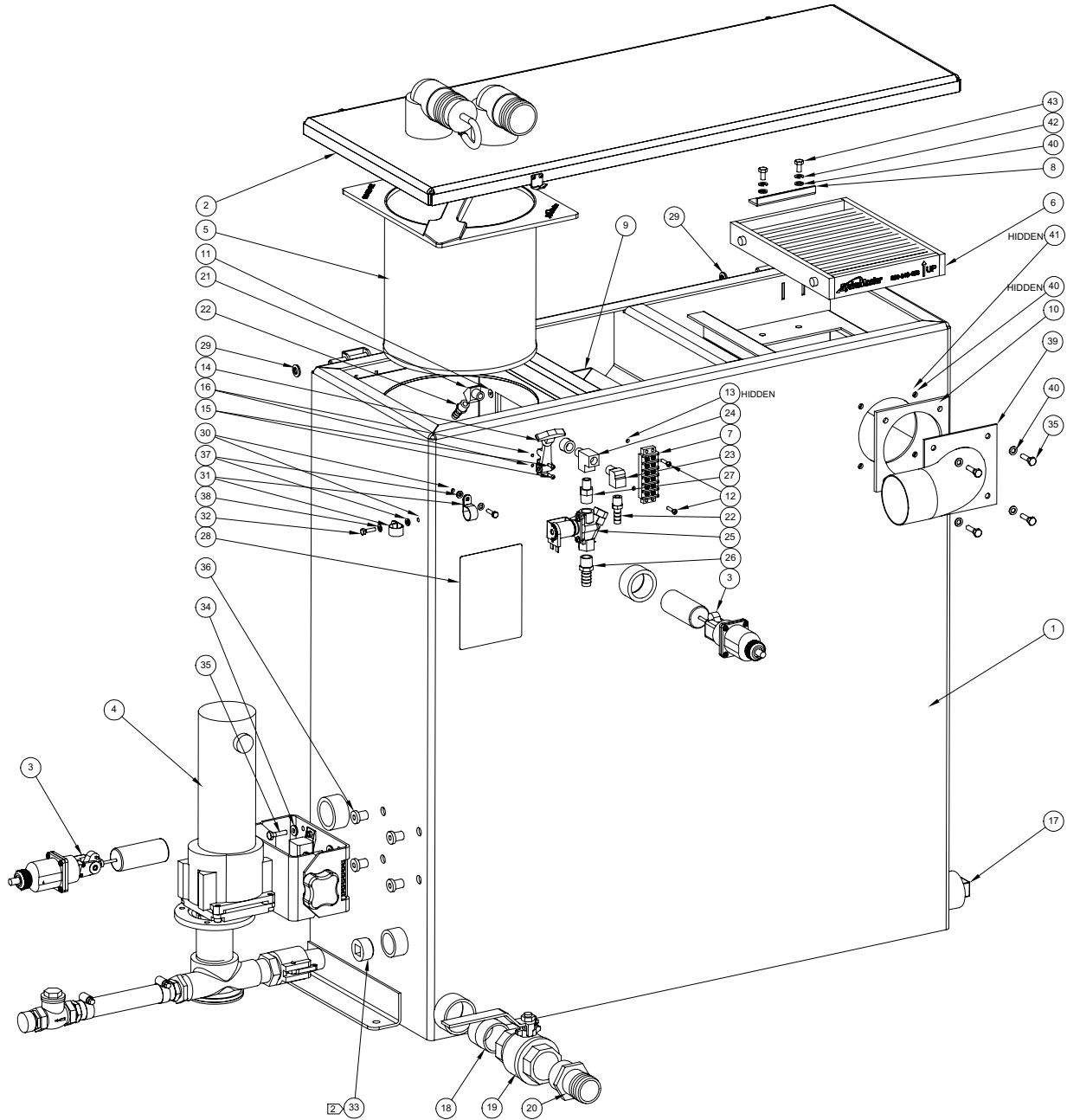

70 Gallon Univesal Recovery Tank Assembly Parts List

Item	Part Number	Description	Qty
1	000-159-128	Tank, 70 Gallon Universal Recovery - Weldment	1
2	610-003-015	Assembly, Cover - Dual Vac. (Fig. 1-35)	1
3	000-157-090	Float, Lever Switch	2
4	000-079-091	Kit, Dura-Flow APO - Production (Fig. 1-39)	1
5	000-049-152	Filter, Recovery Tank Basket	1
6	000-049-153	Filter, Flat - Recovery Tank	1
7	000-012-002	Block, 6 Post Terminal	1
8	000-015-932	Bracket, Flat Filter Securing - Universal Recovery Tank	1
9	000-049-154	Deflector, Air - Univeral Recovery Tank	1
10	000-057-206	Gasket, Adapter - Universal Recovery Tank	1
11	000-140-023	Rivet, AB8-6A Aluminum Pop	6
12	000-143-051	Screw, #8-32UNC x 0.75" Lg. Binder Head Phillips	2
13	000-094-059	Nut, #8-32UNF Nylock	2
14	000-086-008	Latch, Bungie	1
15	000-143-539	Screw, #6-32UNC x 0.50" Lg. Button Head Allen	2
16	000-094-063	Nut, #6-32UNC Nylock	2
17	000-106-019	Plug, 1-1/2" NPT	1
18	000-052-763	Nipple, 1-1/2" LPS Close s/s	1
19	000-169-022	Valve, 1-1/2" Full Port Ball	1
20	000-052-226	Insert, 1-1/2" NPT x 1-1/2" Barb (Grey)	1
21	000-052-082	Elbow, 1/4" NPT Street x 45°	1
22	000-052-102	Insert, #46 (1/4" NPT x 3/8" Barb)	2
23	000-052-085	Elbow, 1/4" NPT Street	1
24	000-052-090	Tee, 1/4" NPT Branch M-F-F	1
25	000-169-120	Valve, Chemical & Hi-Temp Solenoid - 12 Volt	1
26	000-052-105	Insert, #68 (3/8" NPT x 1/2" Barb)	1
27	000-052-073	Nipple, 3/8" NPT x 1/4" NPT Hex	1
28	000-081-241	Label, Maintenance & Lubrication Schedule (Part of set)	1
29	000-174-029	Washer, 3/8" Rubber Back	2
30	000-094-034	Nut, #10-24UNC Nylock	4
31	000-033-023	Clamp, 3/4" Nylon Hose	2

70 Gallon Universal Recovery Tank Assembly Parts List

Item	Part Number	Description	Qty
32	000-143-132	Screw, #10-24UNC x 0.75" Lg. Hex Head	2
33	000-106-049	Plug, 1" NPT Allen Head	1
34	000-174-060	Washer, 1/4" Flat Rubber Backed	4
35	000-143-002	Screw, 1/4"-20UNC x 1.00" Lg. Hex Head	8
36	000-094-113	Nut, 1/4"-20UNC Neoprene Wellnut	4
37	000-174-036	Washer, #10 Flat Rubber Backed	2
38	000-174-001	Washer, #10 Flat	2
39	000-001-135	Adapter, Tank To Ø3.0" x 90° Blower Hose - Universal	1
40	000-174-003	Washer, 1/4" Flat	10
41	000-094-009	Nut, 1/4"-20UNC Hex Nylock	4
42	000-174-019	Washer, 1/4" Lock	2
43	000-143-333	Screw, 1/4"-20UNC x 0.50" Lg. Hex Head	2

Figure 1-35 70 Gallon Universal Recovery Tank Cover Assembly
D-6890 Rev -

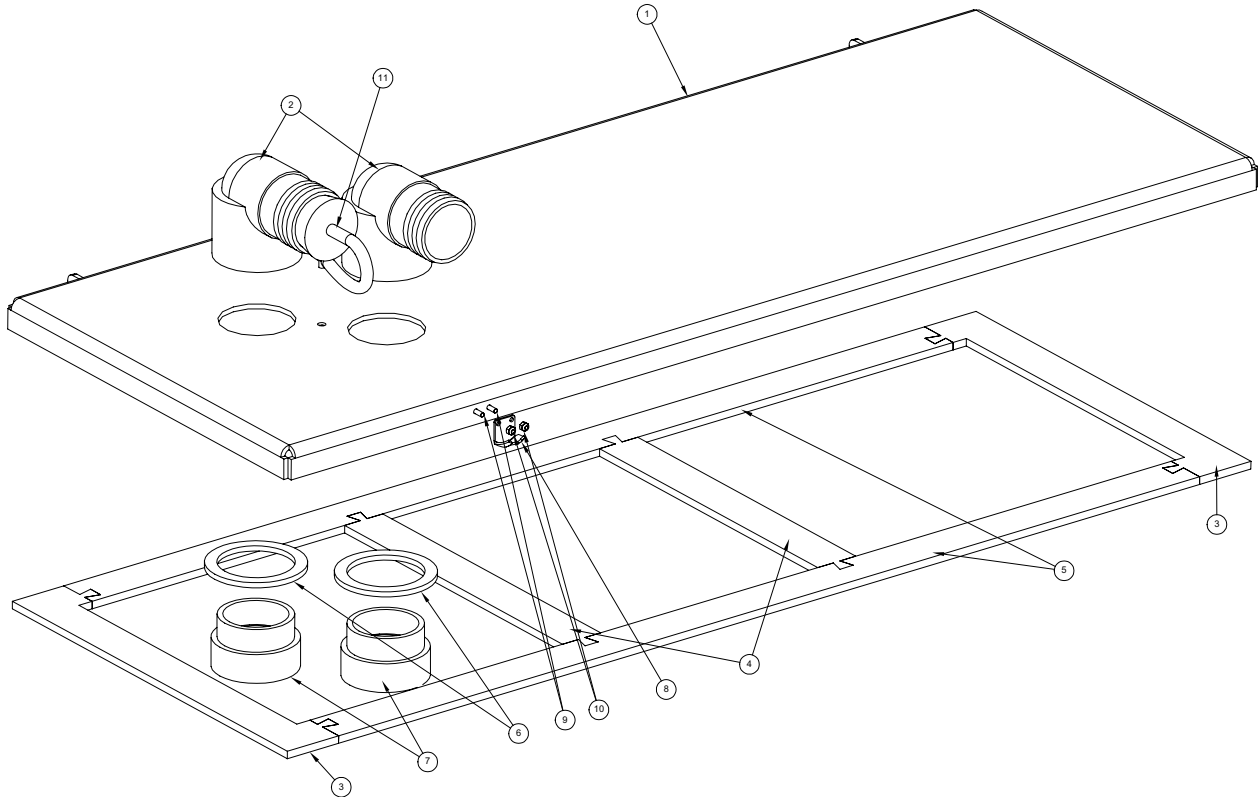

70 Gallon Universal Recovery Tank Cover Assembly Parts List

Item	Part Number	Description	Qty
1	000-041-444	Cover, Dual Vac. 70 Gallon Universal Recovery Tank -	1
2	000-052-222	Elbow, 2" Barb x 2" FPT	2
3	000-057-202	Gasket, End - Recovery Tank	2
4	000-057-203	Gasket, Middle - Recovery Tank	2
5	000-057-204	Gasket, Side - Recovery Tank - 70 Gallon	2
6	000-057-015	Gasket, 1-1/2" Bulkhead Fitting	2
7	000-052-219	Adapter, 2" NPT x 2" F Slip	2
8	000-086-008	Latch, Bungie - Strike	1
9	000-143-539	Screw, #6-32UNC x 0.50" Lg. Button Head Allen	2
10	000-094-063	Nut, #6-32UNC Nylock	2
11	000-078-039	Vacuum Inlet Stopper Assembly - Recovery Tank	1

Figure 1-36 100 Gallon Universal Recovery Tank w/ APO Assembly
D-6983 Rev A

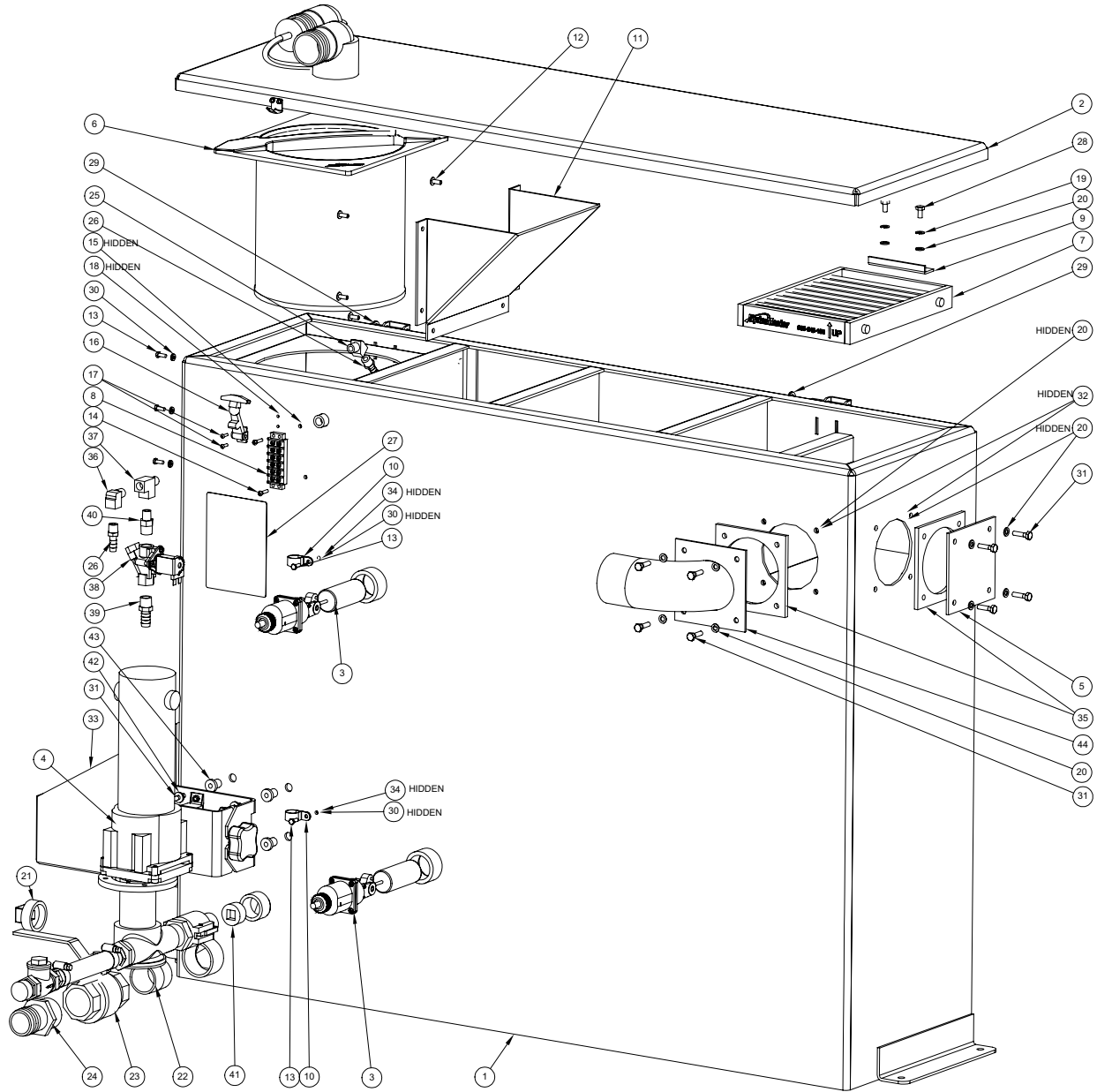

100 Gallon Universal Recovery Tank Assembly Parts List

Item	Part Number	Description	Qty
1	000-159-129	Tank, 100 Gallon Universal Recovery - Weldment	1
2	Fig -1-37	Assembly, Recovery Tank Cover - 100 Gallon	1
3	000-157-090	Float, Lever Switch	2
4	000-079-091	Kit, Dura-Flow APO - Production (Fig 1-39)	1
5	000-105-336	Plate, Vacuum Port Cover - 100 Gallon Universal Recov	1
6	000-049-152	Filter, Recovery Tank Basket	1
7	000-049-153	Filter, Flat - Recovery Tank	1
8	000-012-002	Block, 6 Post Terminal	1
9	000-015-932	Bracket, Flat Filter Securing - Universal Recovery Tank	1
10	000-033-023	Clamp, 3/4" Nylon Hose	2
11	000-049-154	Deflector, Air - Univeral Recovery Tank	1
12	000-140-023	Rivet, AB8-6A Aluminum Pop	6
13	000-143-126	Screw, #10-24UNC x 0.50" Lg. Hex Head	5
14	000-143-051	Screw, #8-32UNC x 0.75" Lg. Binder Head Phillips	2
15	000-094-059	Nut, #8-32UNF Nylock	2
16	000-086-008	Latch, Bungie	1
17	000-143-539	Screw, #6-32UNC x 0.50" Lg. Button Head Allen	2
18	000-094-063	Nut, #6-32UNC Nylock	2
19	000-174-019	Washer, 1/4" Lock	2
20	000-174-003	Washer, 1/4" Flat	18
21	000-106-019	Plug, 1-1/2" NPT	1
22	000-052-763	Nipple, 1-1/2" LPS Close s/s	1
23	000-169-022	Valve, 1-1/2" Full Port Ball	1
24	000-052-226	Insert, 1-1/2" NPT x 1-1/2" Barb (Grey)	1
25	000-052-082	Elbow, 1/4" NPT Street x 45°	1
26	000-052-102	Insert, #46 (1/4" NPT x 3/8" Barb)	2
27	000-081-241	Label, Maintenance & Lubrication Schedule (Part of set)	1
28	000-143-333	Screw, 1/4"-20UNC x 0.50" Lg. Hex Head	2
29	000-174-029	Washer, 3/8" Rubber Back	2
30	000-174-036	Washer, #10 Flat Rubber Backed	5

100 Gallon Universal Recovery Tank Assembly Parts List

Item	Part Number	Description	Qty
31	000-143-002	Screw, 1/4"-20UNC x 1.00" Lg. Hex Head	12
32	000-094-009	Nut, 1/4"-20UNC Hex Nylock	8
33	000-166-002	Tray, Soap Jug - Weldment	1
34	000-094-034	Nut, #10-24UNC Nylock	2
35	000-057-206	Gasket, Adapter - Universal Recovery Tank	2
36	000-052-085	Elbow, 1/4" NPT Street	1
37	000-052-090	Tee, 1/4" NPT Branch M-F-F	1
38	000-169-120	Valve, Chemical & Hi-Temp Solenoid - 12 Volt	1
39	000-052-105	Insert, #68 (3/8" NPT x 1/2" Barb)	1
40	000-052-073	Nipple, 3/8" NPT x 1/4" NPT Hex	1
41	000-106-049	Plug, 1" NPT Allen Head	1
42	000-174-060	Washer, 1/4" Flat Rubber Backed	4
43	000-094-113	Nut, 1/4"-20UNC Neoprene Wellnut	4
44	000-001-135	Adapter, Tank To Ø3.0" x 90° Blower Hose - Universal	1

Figure 1-37 100 Gallon Universal Recovery Tank Cover Assembly
D-6919 Rev -

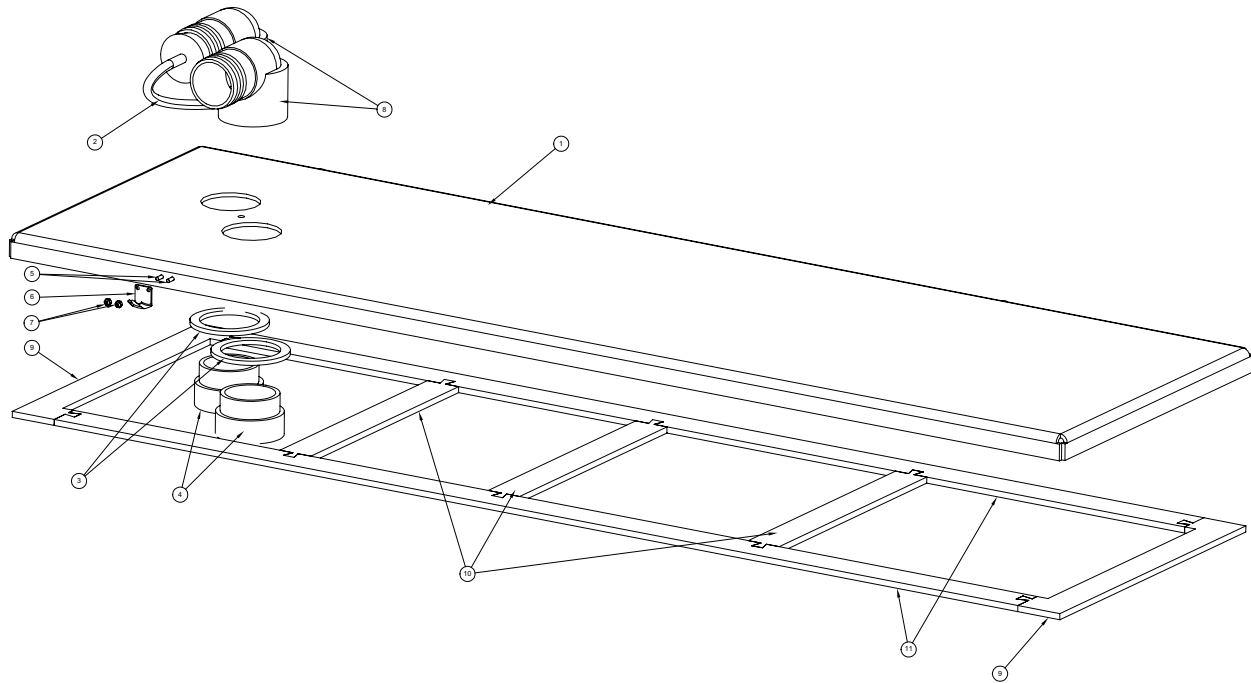

100 Gallon Universal Recovery Tank Cover Assembly Parts List

Item	Part Number	Description	Qty
1	000-041-447	Cover, 100 Gallon Universal Recovery Tank - Weldment	1
2	000-078-039	Vacuum Inlet Stopper Assembly - Recovery Tank	1
3	000-057-015	Gasket, 1-1/2" Bulkhead Fitting	2
4	000-052-219	Adapter, 2" NPT x 2" F Slip	2
5	000-143-539	Screw, #6-32UNC x 0.50" Lg. Button Head Allen	2
6	000-086-008	Latch, Bungie - Strike	1
7	000-094-063	Nut, #6-32UNC Nylock	2
8	000-052-222	Elbow, 2" Barb x 2" FPT	2
9	000-057-202	Gasket, End - Recovery Tank	2
10	000-057-203	Gasket, Middle - Recovery Tank	3
11	000-057-205	Gasket, Side - Recovery Tank - 100 Gallon	2

Figure 1-38 Vacuum Relief Valve Assembly (Collector Box)
C-7156 Rev -

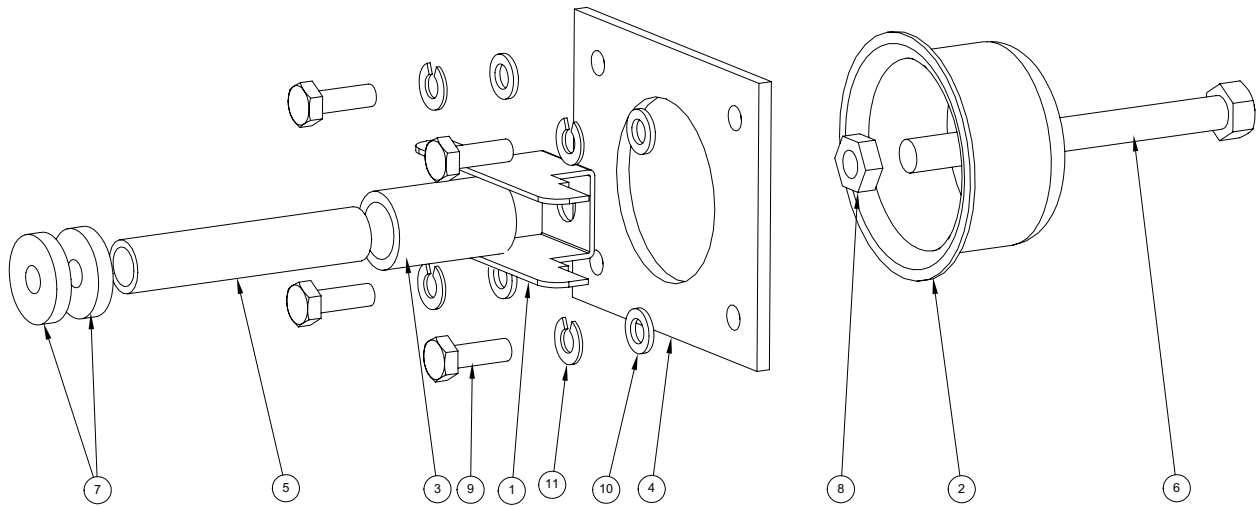

Vacuum Relief Valve Assembly (Collector Box) Parts List

Item	Part Number	Description	Qty
1	000-015-182	Bracket, Vacuum Relief Valve	1
2	000-027-032	Cap, Vacuum RelEIF Valve	1
3	000-125-111	Pipe, Vacuum Relief Spring Guide	1
4	000-105-337	Plate, Vacuum Relief Valve Mounting	1
5	000-155-026	Spring, Vacuum Relief	1
6	000-143-198	Screw, 3/8"-16UNC x 4" Lg. Hex Head Full Thread	1
7	000-094-077	Nut, 3/8"-16UNC x 1.00" O.D. Knurled	2
8	000-094-101	Nut, 3/8"-16UNC Hex Jam	1
9	000-143-001	Screw, 1/4"-20UNC x 0.75" Lg. Hex Head	4
10	000-174-003	Washer, 1/4" Flat	4
11	000-174-019	Washer, 1/4" Lock	4

Figure 1-39 Dura-Flow APO Pump Assembly
D-5654 Rev E

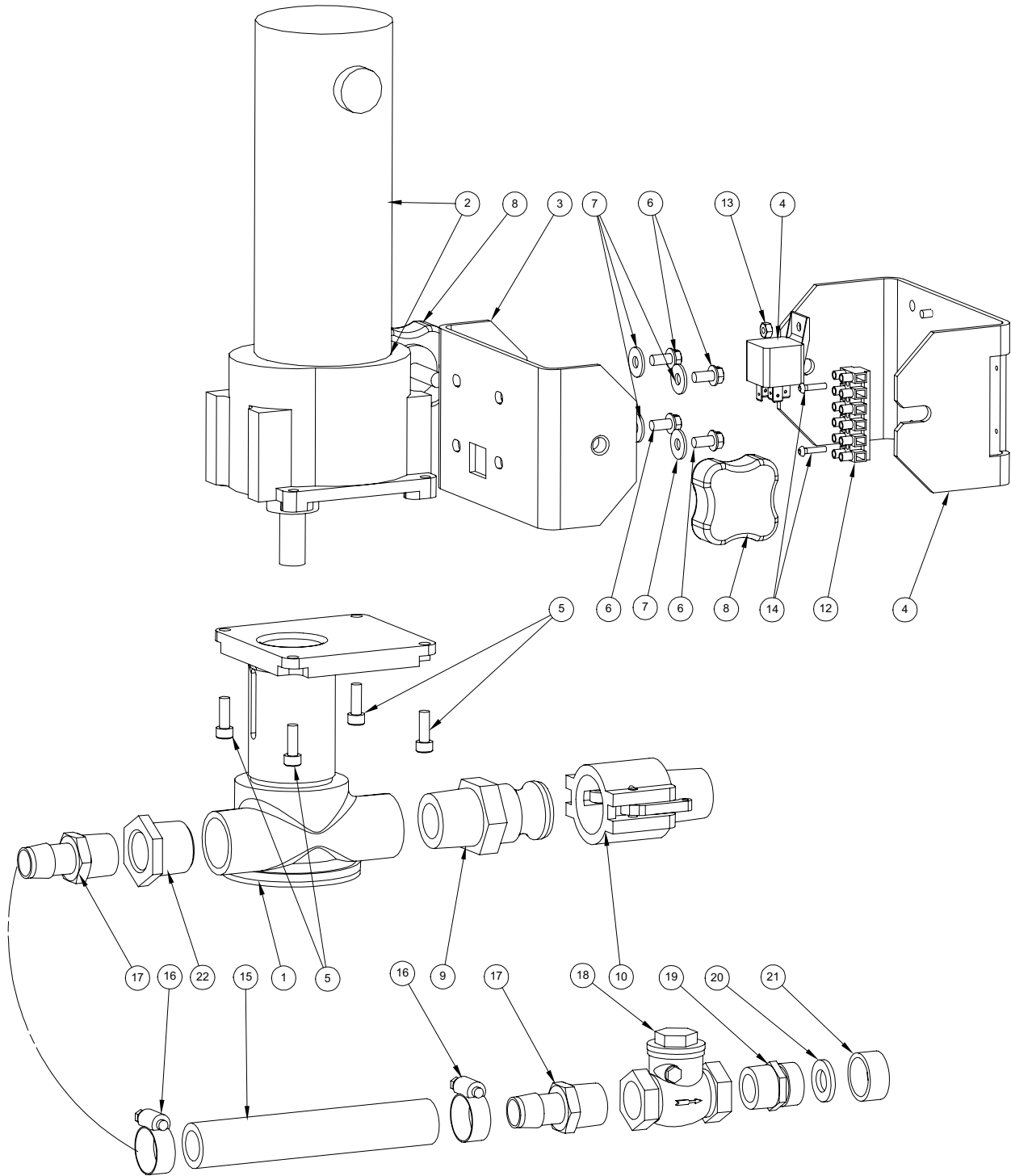

Dura-Flow APO Pump Assembly Parts List

Item	Part Number	Description	Qty
1	000-111-169	Assembly, APO Pump - Jabsco	1
2	000-091-042	Motor, Bison 438 Series	1
3	000-015-891	Bracket, APO Clamp	1
4	000-015-890	Bracket, Tank Mounted APO Support	1
5	000-143-566	Screw, 1/4-28UNF x 0.75" Lg. Socket Head	4
6	000-143-074	Screw, 1/4"-20UNC x 0.50" Lg. Hex Head Self-Tapping	4
7	000-174-002	Washer, 1/4" Flat	4
8	000-061-131	Knob, Handle - Rdm	2
9	000-052-723	Fitting, 1" NPT Cam Lock - Banjo 100F	1
10	000-052-724	Fitting, 1" NPT Cam Lock - Banjo 100B	1
11	000-157-022	Switch, Relay	1
12	000-012-011	Block, 6 Post	1
13	000-094-027	Nut, #10-24UNC Hex	1
14	000-143-532	Screw,#6-32UNC x 5/8" Lg. Socket Head	2
15	000-068-069	Hose, 3/4" I.D. Weatherhead - Blue - Bulk.	1
16	000-033-026	Clamp, Size #10 Hose	2
17	000-052-338	Insert, #1212 (3/4" NPT x 3/4" Barb)	2
18	000-169-009	Valve, 3/4" FPT Swing Check	1
19	000-052-281	Nipple, 3/4" NPT x 3/4" Male Garden Hose	1
20	000-057-055	Gasket, Garden Hose	1
21	000-027-014	Cap, Garden Hose	1
22	000-052-425	Bushing, 1" NPT x 3/4" FPT	1

Figure 1-40 Chemical Jug Tray Assembly
C-4945 Rev C

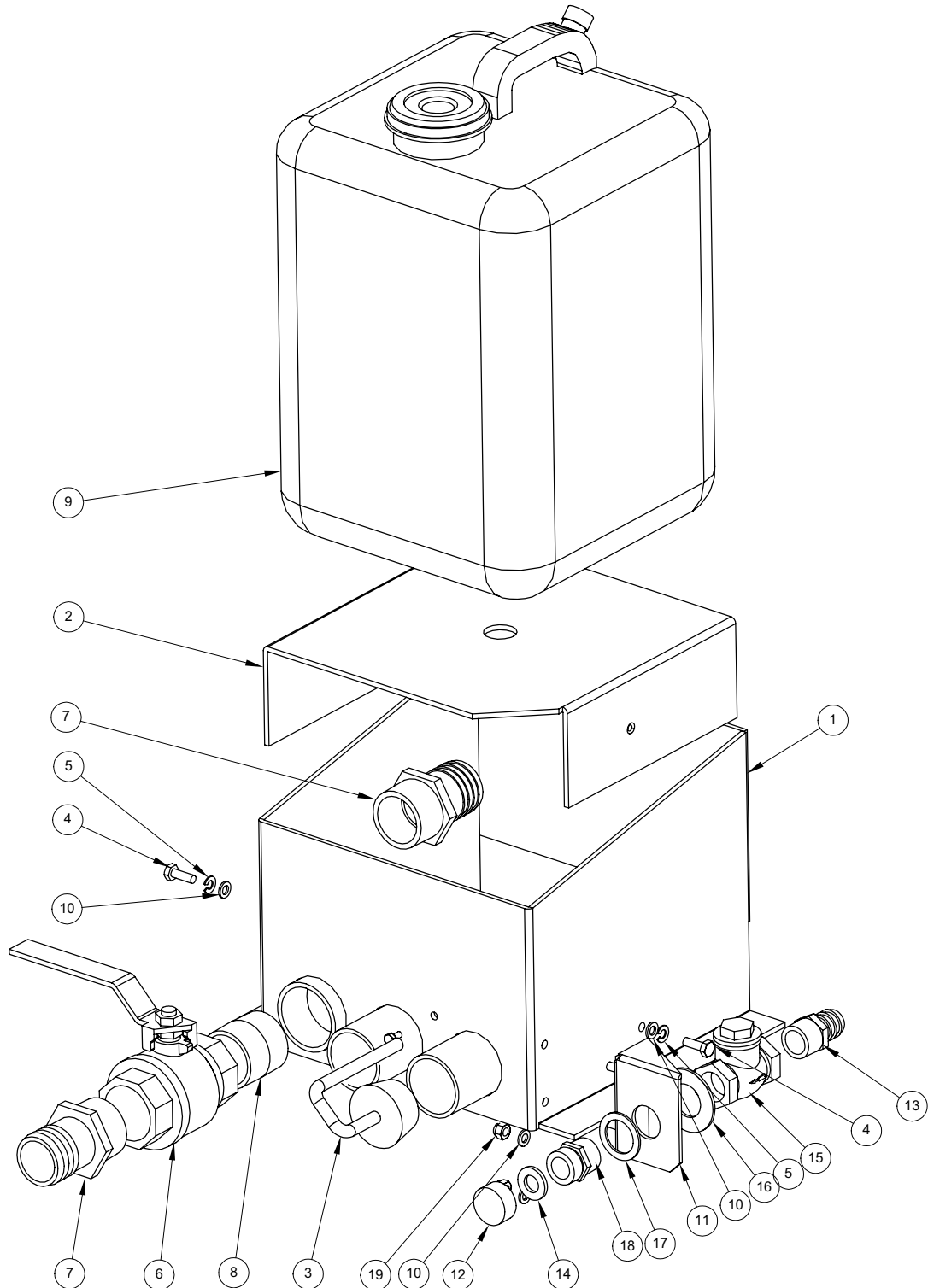

Chemical Jug Tray Assembly Parts List

Item	Part Number	Description	Qty
1	000-166-021	Tray, Chemical Jug - Outer - Weldment	1
2	000-166-025	Tray, Chemical Jug - Inner	1
3	000-078-039	Vacuum Inlet Stopper	1
4	000-143-001	Screw, 1/4"-20UNC x 0.75" Lg. Hex Head	2
5	000-174-019	Washer, 1/4" Lock	2
6	000-169-022	Valve, 1-1/2" Full Port Ball	1
7	000-052-226	Insert, 1-1/2" NPT x 1-1/2" Barb (Grey)	2
8	000-052-182	Nipple, 1-1/2" NPT Close Galvanized	1
9	000-159-016	Jug, 5 Gallon Plastic Chemical - Standard	1
10	000-174-003	Washer, 1/4" Flat	4
11	000-015-720	Bracket, Apo Outlet Mounting - Weldment	1
12	000-027-014	Cap, Garden Hose	1
13	000-052-338	Insert, #1212 (3/4" NPT x 3/4" Barb)	1
14	000-057-055	Gasket, Garden Hose	1
15	000-169-009	Valve, 3/4" FPT Swing Check	1
16	000-174-050	Washer, 1" Flat	1
17	000-174-063	Washer, 1.5" O.D. x 1.073" I.D. x 0.075" Thk.	1
18	000-052-281	Nipple, 3/4" NPT x 3/4" Male Garden Hose	1
19	000-094-009	Nut, 1/4"-20UNC Hex Nylock	2

Figure 1-41 Diffuser Filter Assembly
C-6554 Rev -

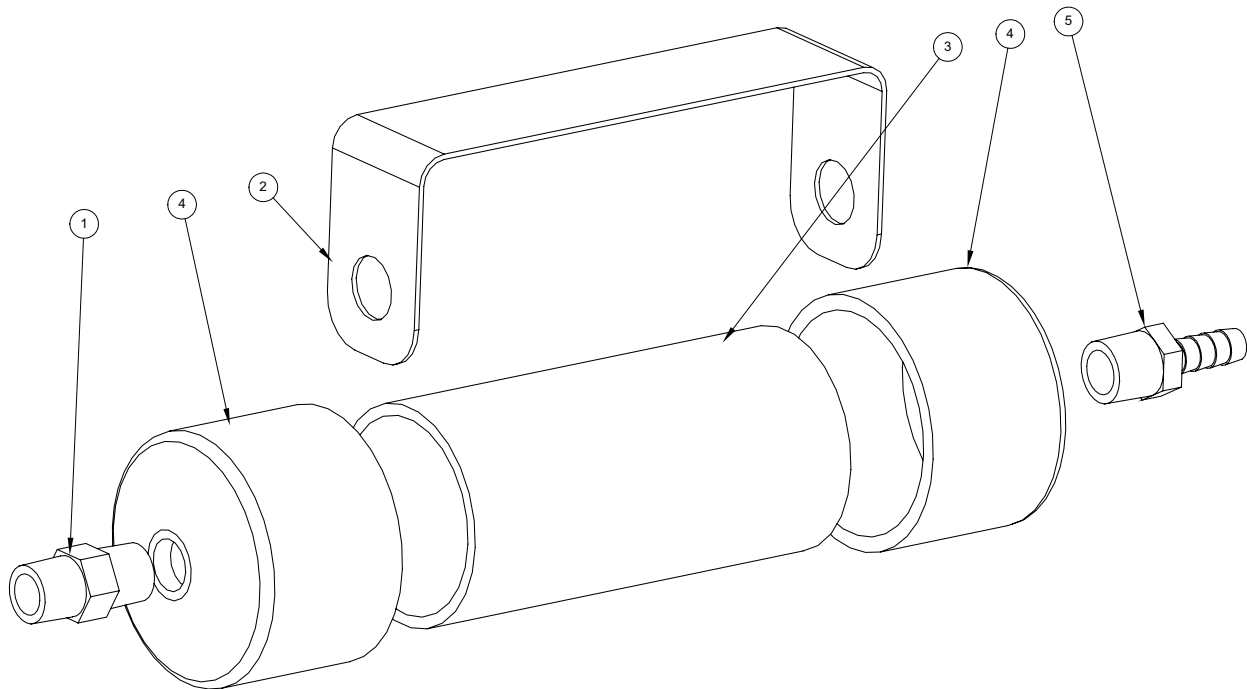

Diffuser Filter Assembly Parts List

Item	Part Number	Description	Qty
1	000-052-074	Nipple, 3/8" NPT Hex	1
2	000-033-131	Clamp, Diffuser - Boxxer 427	1
3	000-125-222	Tube, Diffuser - Boxxer 427	1
4	000-027-115	Cap, 2" PVC Modified For Diffuser - Boxxer 427	2
5	000-052-104	Insert, #66 (3/8" NPT x 3/8" Barb)	1

Figure 1-42 Float Switch w/ Polypropylene Barrel Assembly
C-6549 Rev -

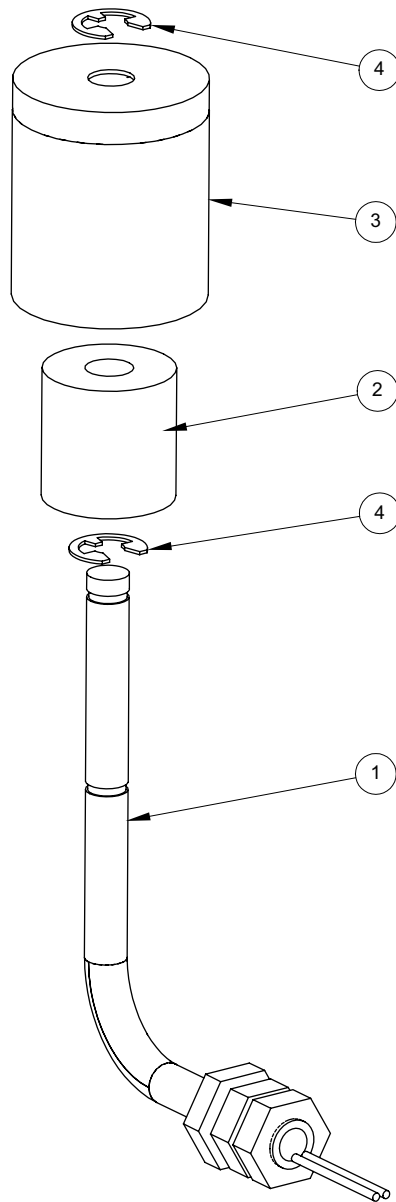

Float Switch w/ Polypropylene Barrel Assembly Parts List

Item	Part Number	Description	Qty
1	- - -	Stem, Float Switch	1
2	000-005-011	Float, Polypropylene Replacement- Boxxer 427	1
3	000-108-110	Shield, Poly Float Splash	1
4	000-139-010	Ring, Snap Ring (E-Clip) x 5/16"	2

Cleaning and Chemicals

Boxxer 427

Section 2-1

Your mobile carpet cleaning plant has been engineered using the latest and most sophisticated technology available to produce the finest carpet cleaning results possible. Despite this, however, it remains only a tool of the carpet cleaning trade, and it can produce only as good a job as the person operating it.

PRECAUTIONS

There are no short cuts to good carpet cleaning. It requires time, cleaning knowledge and the use of good chemicals. Therefore, the manufacturer recommends the use of spotting agents and traffic lane cleaners, as required, prior to the actual cleaning of carpeting.

The use of some chemicals through your mobile carpet cleaning plant can seriously damage the internal plumbing, high pressure pump and heater. These harmful chemicals include concentrated acid (see the pH chart at the end of this section), solvents, and some paint, oil, and grease removers with a high concentration of solvents.

The manufacturer recommends only the use of chemicals containing rust and corrosion inhibitors and water softening agents to prevent chemical buildup which may lead to component failure and warranty invalidation.

CAUTION

The increased demand for "clear water" rinsing results in the need for special care when using these acid based chemicals in your equipment. The negative side of these products is the corrosive effects the acid can have on metals, including swivels, pumps, heat exchangers, etc.

HydraMaster's ***ClearWater Rinse*** has been formulated to protect vital components. HydraMaster will not warranty parts that have been damaged from using unprotected acid products that have obviously caused failures.

CLEANING STROKE PROCEDURE

Purpose:

To eliminate excess moisture remaining in the carpet fiber and the saw tooth appearance which results from diagonal movement of the cleaning tool on all types of carpet.

Procedure:

Always move the cleaning tool in smooth, forward and backward strokes. Apply slight pressure to the forward stroke while the solution is injected into the carpet. When extracting (drying), apply firm pressure on the forward stroke to ensure a positive "lock" for the vacuum and minimize the "hopping" effect resulting on carpet that is not smooth. During the forward and reverse strokes, movement to the right or left should only be accomplished at the extreme rear of the stroke. Overlapping is also important to ensure even application of solution and prevent saturation when cleaning wand is stopped twice at the same point at the rear of the cleaning stroke. This is illustrated at the end of this section.

Failure to adopt this procedure can result in increased chance of "clean streaks," fiber shrinkage, brown-out and longer drying periods.

OVER-WETTING

Over-wetting is annoying to all concerned, and sometimes leaves a bad impression of the cleaning process used.

THESE ARE SEVERAL AREAS THAT WILL CAUSE OVER-WETTING

1. Too few vacuum strokes or improper saw-tooth vacuum strokes as shown in the following illustration.
2. Obstructed, cut or kinked hoses.
3. Vacuum tank drain valve left partially open.
4. Clogged vacuum blower filter or vacuum tank lid not sealing properly.
5. Cleaning a heavily foam-saturated carpet without defoamer. (We recommend crystal type.)

Figure 2-1: pH Chart

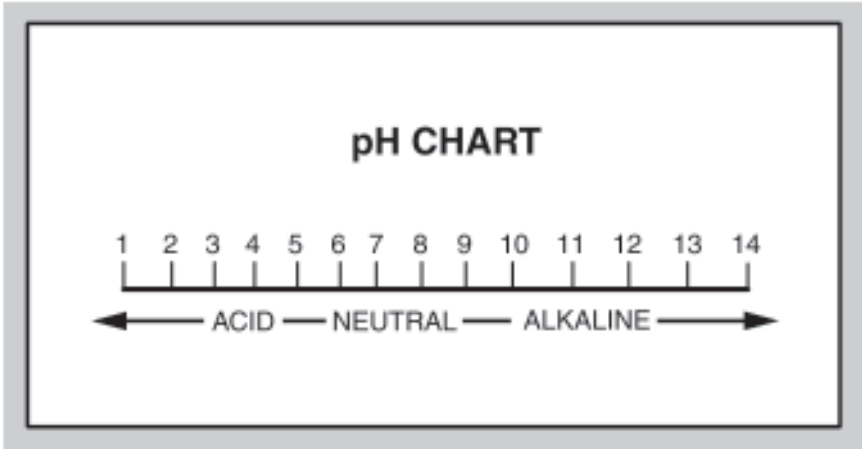
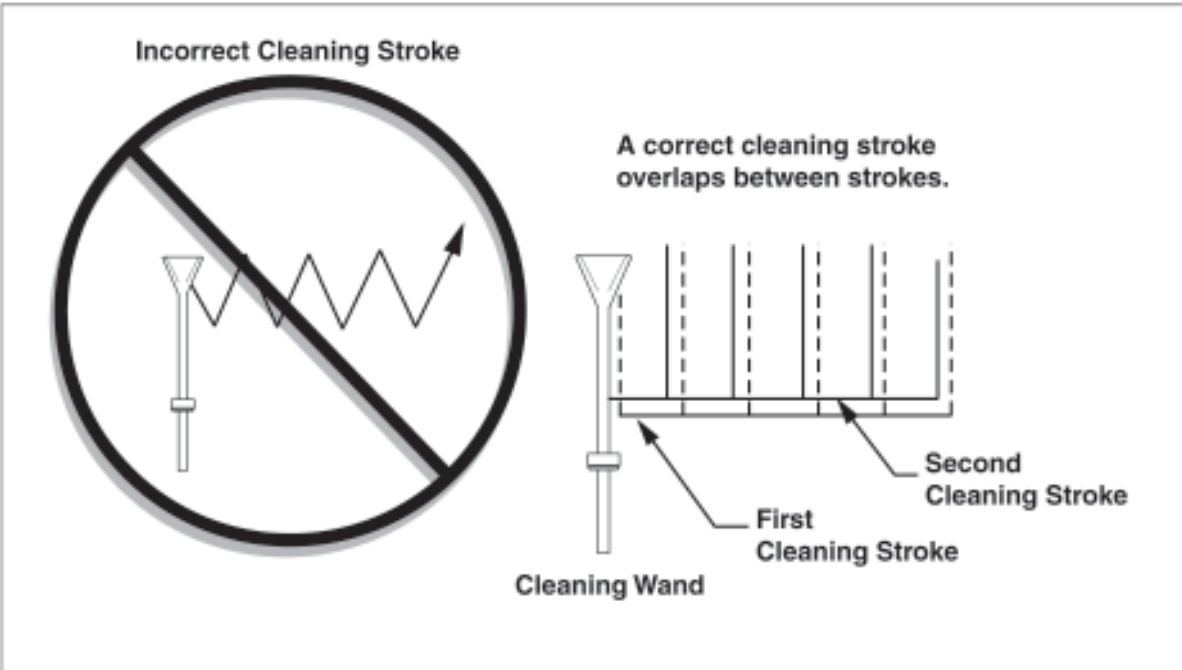

Figure 2-2: Cleaning Stroke Procedure



This page intentionally left blank

Operating Instructions

Boxxer 427

Section 3-1

START UP

1. Perform daily and periodic maintenance as specified in this Owner's Manual.
2. Connect all required hoses, including a garden hose for water supply.
3. Connect the cleaning tool to the length of hose required to perform the cleaning.

 **CAUTION**

Water box must be full prior to ignition.

 **WARNING**

The machine cannot be *run* in the "IDLE" position for cleaning upholstery, carpet or floor extraction. This will void the warranty.

NOTE: In order to achieve consistent adjustable temperatures, an operating pressure of 200 PSI must be maintained.

Note: Never run machine on any speed other than full throttle. Running at any other speed will void the warranty.

Carpet or Hard Surface Cleaning

1. Start the engine with throttle cable in "IDLE" position.
Allow machine to run in idle for **2 - 3 minutes to warm up**.
2. Connect hoses.
3. Connect wand or tool.
4. Pull THROTTLE to "**HIGH**" position.
5. If used, turn PUMP IN switch to "**ON**" .
6. Turn PUMP switch to "**ON**" .
7. Turn DIVERTER switch to "**ON**" .
8. Set temperature to desired level.
9. If used, turn PUMP OUT switch to "**ON**" .

10. Set cleaning pressure at desired level.

Suggested Settings

Carpet Cleaning: 300 – 400 psi;

Hard Surface: 1000 psi or as indicated on the tool.

11. Turn the chemical selector valve to the "PRIME" position to purge any air from the system.
 - a. With the machine running at operating speed, block off the vacuum intake to the recovery tank. The vacuum gauge should read between 12"hg and 14"hg. This will assist in priming the chemical system.
 - b. When the chemical begins to flow through the flowmeter, with the flow indicator reading maximum flow for at least 10 seconds, turn the chemical selector to "ON". The restriction can now be removed from the vacuum inlet.



Do not leave in the "PRIME" position for extended periods of time. Excessive chemicals will be used if it is not switched back to "ON" or "OFF"

- c. Then, while spraying solution from the cleaning tool, adjust the chemical flow by turning the chemical adjustment knob as necessary.
12. Commence cleaning.

Upholstery Cleaning

1. Start engine with the THROTTLE cable in the "IDLE" position. Allow the machine to run in idle for **2 - 3 minutes to warm up.**
2. Connect hoses.
3. Connect the upholstery tool.
4. Pull the THROTTLE to the "HIGH" position.
5. If used, turn the PUMP IN switch to "ON" .
6. Turn the PUMP switch to "ON" .
7. Turn the DIVERTER switch to "ON" .

During upholstery cleaning, if you desire a lower temperature you may want to leave the DIVERTER switch in the "OFF" position. The temperature in the exhaust/blower heat exchanger will be reduced, the heat will be obtained from the engine coolant and reduced blower exhaust heat exchangers.

8. Set the temperature to desired level.
9. If used, turn PUMP OUT switch to **"ON"** (switch light will be illuminated).
10. Set cleaning pressure at desired level (300 –400 psi).
11. Turn the chemical selector valve to the **"PRIME"** position to purge any air from the system.
 - a. With the machine running at operating speed, block off the vacuum intake to the recovery tank. The vacuum gauge should read between 12"hg and 14"hg. This will assist in priming the chemical system.
 - b. When the chemical begins to flow through the flowmeter, with the flow indicator reading maximum flow for at least 10 seconds, turn the chemical selector to **"ON"**. The restriction can now be removed from the vacuum inlet.



Do not leave in the **"PRIME"** position for extended periods of time. Excessive chemicals will be used if it is not switched back to **"ON"** or **"OFF"**

- c. Then, while spraying solution from the cleaning tool, adjust the chemical flow by turning the chemical adjustment knob as necessary.
12. Commence cleaning.

Flood Extraction

1. Start the engine with the THROTTLE cable to the **"IDLE"** position. Allow the machine to run in idle for **2 - 3 minutes to warm up.**
2. Connect hoses.
3. Connect wand or tool.
4. Pull the THROTTLE cable to **the "HIGH"** position.
5. If used, turn PUMP OUT switch to **"ON"** .
6. Commence water extraction.
Note: Make sure the diverter and pump switch are in the **"OFF"** position.

Shut Down

1. Flush clear water through the chemical system for 10 seconds. Turn off the chemical flowmeter.
2. Cool the machine by lowering the adjustable thermostat to the “**LOW**” position and the DIVERTER CONTROL switch to the “**OFF**” position while spraying the cleaning wand into the vacuum hose for three to five minutes. The chemical will be flushed from the unit, hoses and cleaning tool.

NOTE: If the machine is not properly cooled, the water box can overflow.

3. Remove the vacuum hose.
4. At this time, the blower should be lubricated with an oil-based lubricant. See **Lubrication** in the Blower Operation and Maintenance Manual included in Section 8 of this document.

NOTE: If freeze guarding is necessary, perform the freeze guard procedure at this time. (see Section 4 for **Freeze Guarding**)

5. Lower the engine RPMs to idle.
6. Turn the key off.
7. Drain the water box.
8. Drain the vacuum tank. The vacuum filter should be cleaned prior to mobilization of the van.

NOTE: In accordance with the EPA, state and local laws, **do not dispose of waste water into gutters, storm drains, streams, reservoirs, etc.**

9. Perform daily maintenance as prescribed in this manual.

Exhaust Diverter System

The exhaust diverter system consists of two components; the diverter valve and the pump clutch. The diverter valve directs the flow of the exhaust through the coil heat exchanger or directly out of the machine via the diverter exhaust muffler. The pump clutch allows the pump to be turned on and off through a switch. This will enable the machine to be used for flood extraction without the need for an inlet garden hose connected to the machine. Thus preventing excessive filling of the recovery tank through the temperature control system.

The Boxxer 421 can run in two different modes:

Cleaning Mode

To run the machine in Cleaning mode:

- a) Turn the pump and diverter switch to the "ON" position.
- b) Adjust thermostat knob to desired temperature.

Flood Damage Mode

To run the machine in Flood Damage mode:

- a) Turn the pump and diverter switch to the "OFF" position.
- b) Drain waterbox completely.

CAUTION

HOT SURFACES: When the machine is being run or after it has been shut down, caution should be used around the muffler and the exhaust diverter surfaces as they become hot during operation.

WARNING

Do not use excessive force when engaging and disengaging the heat exchanger bypass lever. This may cause damage to the exhaust diverter.

WARNING

In order for the valve to operate properly, it should periodically be engaged and disengaged.

Adjustment After Installation:

Machines that are equipped with a diverter valve may need adjustment after the machine has been installed.

Prior to running the machine, perform the following steps:

1. Locate the actuator connected to the diverter valve arm which is located on the lower left hand side, behind the diverter valve.
2. The actuator shaft is connected to the diverter valve arm. Pull the actuator shaft forward and listen to hear if the poppet seals against the seat in the diverter valve. Push the actuator shaft back and listen to see if the poppet seals against the seat in the diverter valve.

If the poppet **seats** in both directions, the diverter actuator is in proper adjustment.

If the poppet **does not** seat in one or both directions the valve is out of adjustment. Perform the following steps to adjust the diverter actuator shaft.

3. The end of the actuator shaft is threaded into the diverter arm and is secured into position with a backup nut. This nut must be loosened to allow adjustment.
4. Loosen the actuator backup nut. This will allow you to rotate the actuator shaft clockwise or counterclockwise. Rotate the actuator shaft one half turn at a time. Then pull the actuator shaft forward and back. Listen to hear if the poppet seals in the seat of the diverter valve. Repeat this step until the diverter poppet seals in both directions.
5. Apply red Loctite on the thread of the actuator shaft. Retighten the backup nut.
6. Recheck the adjustment. Move the actuator shaft forward and back. Listen to hear if the diverter poppet seals in both directions. The diverter is now properly adjusted.

Freeze Guard

Boxxer 427

Section 4-1

FREEZE GUARD PROCEDURE:

To freeze guard your machine:

1. Start the machine.
2. Spray all of the water out of the system until the engine stops.
3. Add a half gallon of 50/50 antifreeze and water mix to the chemical mix tank and draw the antifreeze into the flow meter.

When using the recirculation kit (part no. 078-058), fill a third of the mix tank with a 50/50 antifreeze mix. Verify that the upper float is not lying horizontal, but floats below.

Attach the recirculation fitting provided in the kit to the garden hose quick connect (see Fig. 4-1) and this combination to the front of the machine.

Figure 4-1 Recirculation Fitting

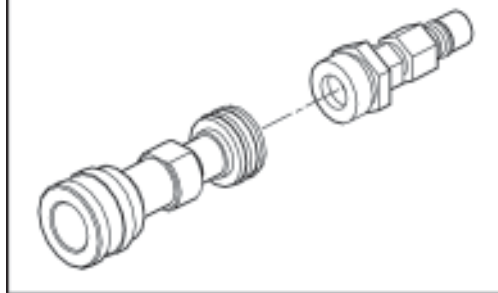

Attach one section of female/female solution hose to the outgoing solution fitting on the front of the machine and the other end to the garden hose and recirculation fitting combination that is attached to the front of the machine (or as many sections as you want, if you wish to freeze guard your hoses).

4. Start the machine. Allow it to run for 2 to 3 minutes.

With the recirculation kit, skip ahead to step 6.

5. Remove the quick connect fitting from the end of the garden hose. Attach the garden hose quick connect to the machine. Using a vacuum hose attached to the recovery tank, vacuum the water out of the garden hose quick connect.

6. Spray the antifreeze and water mix out of the machine and into a container to reclaim the solution. Run the machine until it stops.

NOTE: The reclaimed antifreeze solution may be used 3 times before being discarded.

NOTE: To freeze guard hoses and wand, perform the above step with all the hoses and wand attached.

The machine is now freeze guarded. Remember to flush antifreeze from the system prior to carpet cleaning.

Recovering Antifreeze For Re-use:

Before cleaning with the machine again, flush the remaining antifreeze solution from the system into a sealable container so that it may be used again. To do this, spray water through the hoses and wand until all signs of antifreeze are gone.

 **CAUTION**

One manufacturer of antifreeze cautions: **“WHEN DISPOSING OF USED ANTIFREEZE COOLANT:** Follow local laws and regulations. If required, dispose at facilities licensed to accept household hazardous waste. If permitted, dispose in sanitary sewer systems. Do not discard into storm sewers, septic systems, or onto the ground.”

 **WARNING**

This warning appears on the label of one brand of antifreeze: **“HARMFUL OR FATAL IF SWALLOWED.** Do not drink antifreeze coolant or solution. If swallowed, induce vomiting immediately. Call a physician. Contains Ethylene Glycol which caused birth defects in animal studies. Do not store in open or unlabeled containers.

“KEEP OUT OF REACH OF CHILDREN AND ANIMALS.”

FREEZE PROTECTION OF THE PUMP-IN SYSTEM

1. Drain the fresh water tank.
2. Remove the garden hose adapter from the pump-in pump hose and position the hose so it is pointing outside the van.
3. Turn on the pump-in pump and run for 1-2 minutes till all the water is purged from the hose.

NOTE: The next time the unit is used it may take a few minutes before the mix tank begins to fill.

This page intentionally left blank.

Water and Chemical System

Boxxer 427

Section 5-1

This high pressure chemical system has been designed to be simple and trouble free.

WATER AND CHEMICAL FLOW OPERATION

The chemical pump draws the chemical from the inlet filter which is in the chemical container. It flows through the flow meter indicating the GPH's of chemical being used. The chemical then flows through the chemical pump to the chemical selector valve. The chemical valve can be used to prime the pump (evacuate air from the system), inject chemical into the system or turn the chemical flow off. In the "ON" position, chemical flows through the metering valve, and is injected into the heated water path just prior to its leaving the machine.

The low water float switch in the water box, is a safety switch that is designed to protect your system from sudden or unexpected loss of water supply. If, for example, the water source at the house were turned off, the water level of the water box would drop, activating the low water float switch, which automatically disengages the system and prevents the water pump from running dry.

The desired chemical injection ratio may be obtained by an adjustment of the chemical flowmeter during the spraying of water through the cleaning tool.

BEFORE CLEANING BEGINS:

1. Turn the chemical selector valve to the "PRIME" position to purge any air from the system.
 - a. With the machine running at operating speed, block off the vacuum intake to the recovery tank. The vacuum gauge should read between 12"hg and 14"hg. This will assist in priming the chemical system.

- b. When the chemical begins to flow through the flowmeter, with the flow indicator reading maximum flow for at least 10 seconds, turn the chemical selector to "ON". The restriction can now be removed from the vacuum inlet.

 **CAUTION**

Do not leave in the "PRIME" position for extended periods of time. Excessive chemicals will be used if it is not switched back to "ON" or "OFF"

- c. Then, while spraying solution from the cleaning tool, adjust the chemical flow by turning the chemical adjustment knob as necessary.

BEFORE CLEANING BEGINS (cont.):

2. When the chemical begins to flow through the flowmeter, with the flow indicator indicating maximum flow and the PRIME line pulsing, turn the Chemical Selector Valve to "ON".
3. Place the Chemical PRIME Line back into the chemical container.
4. While spraying solution from the cleaning tool, adjust the chemical flow by turning the Chemical Adjustment Knob as necessary.

CHEMICAL SYSTEM MAINTENANCE

The chemical lines may need to be flushed with vinegar periodically to prevent abnormal chemical build-up. This flushing may be done by removing the clear plastic hose from the chemical jug and inserting it into a one quart container of vinegar. This should be done with the chemical flowmeter setting 10 GPH. Simply spray water from the wand until the quart of vinegar is exhausted. Then repeat the process with one quart of clear water to void all lines of vinegar.

Figure 5-1 Chemical Pump Assembly

C-6555 Rev -

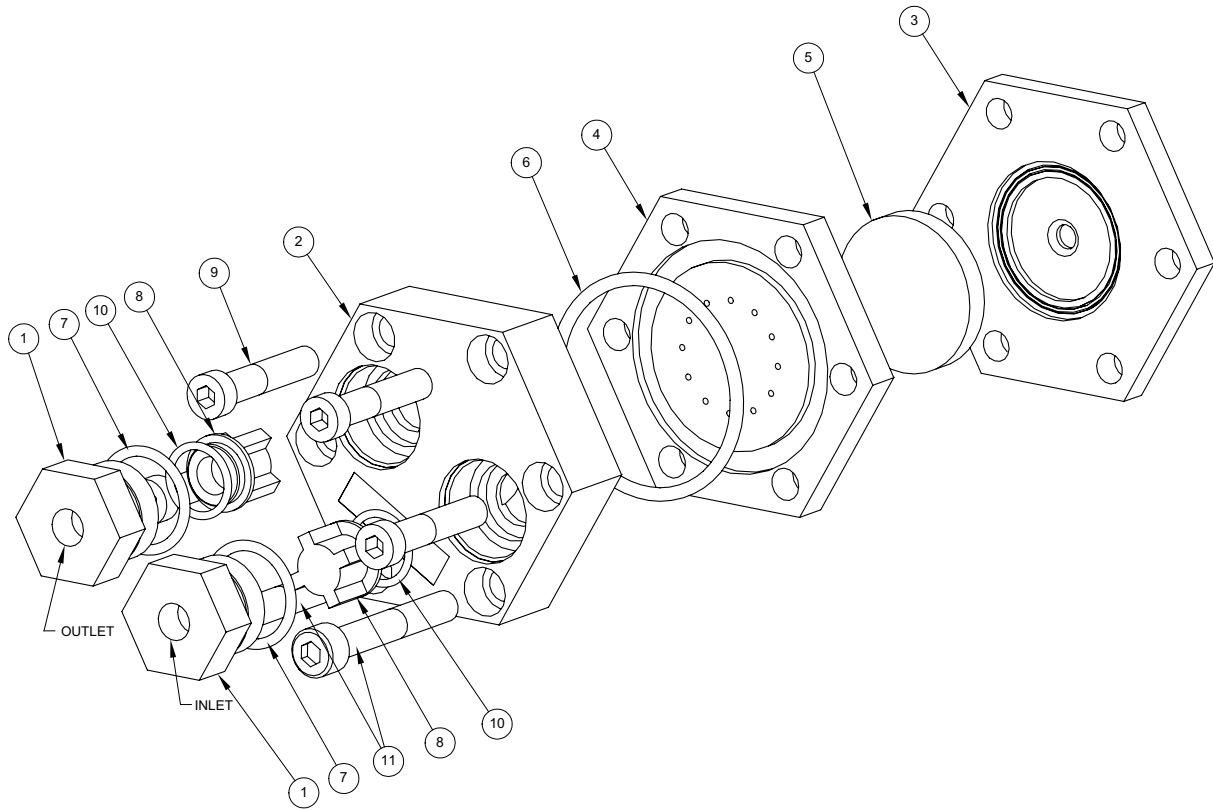

Chemical Pump Assembly Parts List

Item	Part Number	Description	Qty
1	000-106-110	Plug, Check Valve - Chemical Pump	2
2	000-064-015	Cover, Chemical Pump	1
3	000-111-030	Body, Chemical Pump	1
4	000-105-071	Mid Plate, Chemical Pump	1
5	000-046-010	Diaphragm, Chemical Pump	1
6	000-097-055	O-Ring, Chemical Pump Midplate AN Size -227 Viton	1
7	000-097-056	O-Ring, Check Valve Plug - Chemical Pump	2
8	000-169-155	Valve, Check, - Last Step Chemical Injection	2
9	000-143-152	Screw, 5/16"-24UNF x 1.50" Lg. Socket Head	4
10	000-097-054	O-Ring, Chem. Pump Valve Viton-Parker 2-114	2
11	000-143-574	Screw, 5/16"-24UNF x 2" Lg. Soc. Head Grade L9	2

This page intentionally left blank

Figure 5.2, Solution Flow Diagram

D5736 Rev A

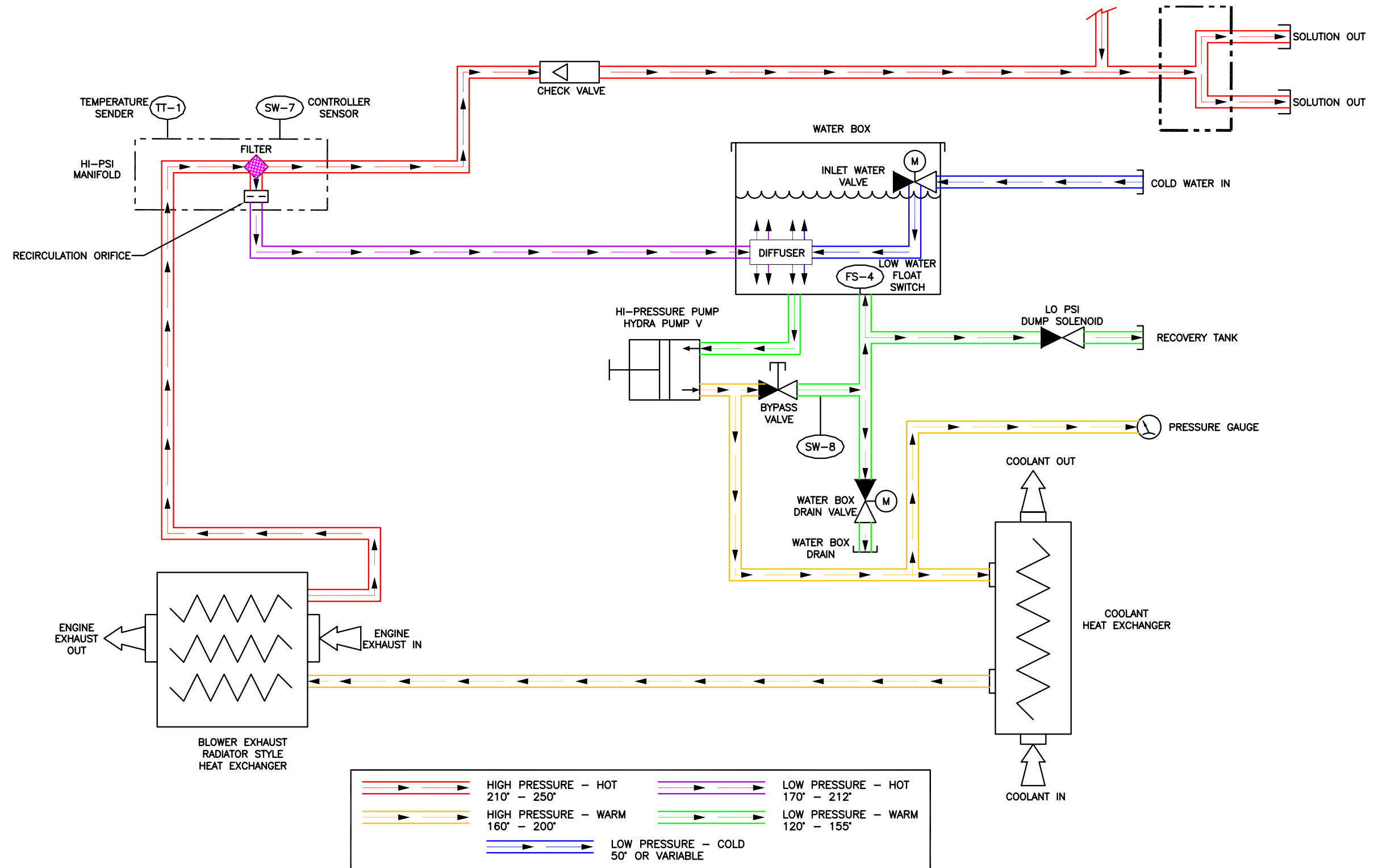

Figure 5.3, Chemical Flow Diagram

D5736, Rev A

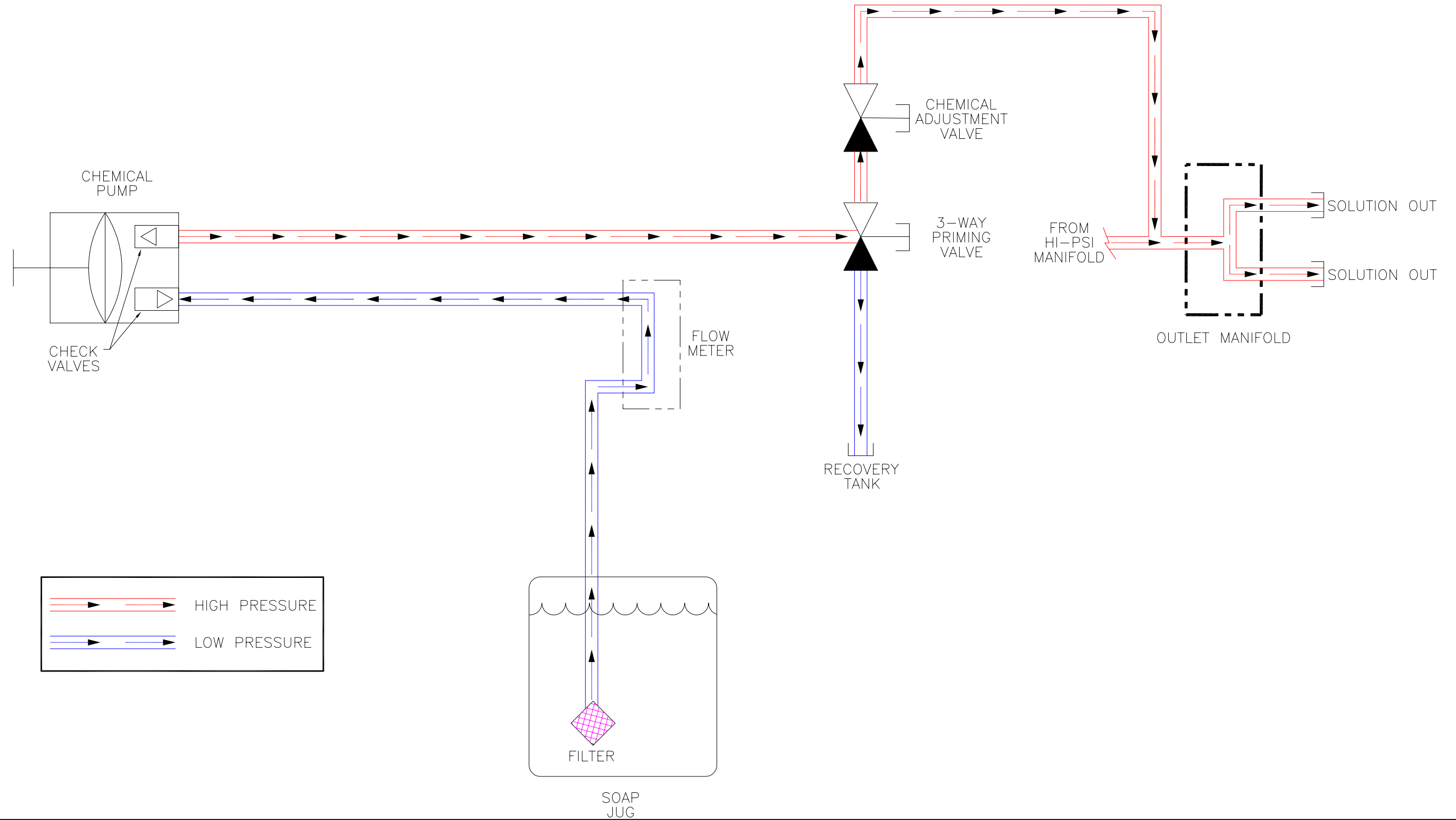
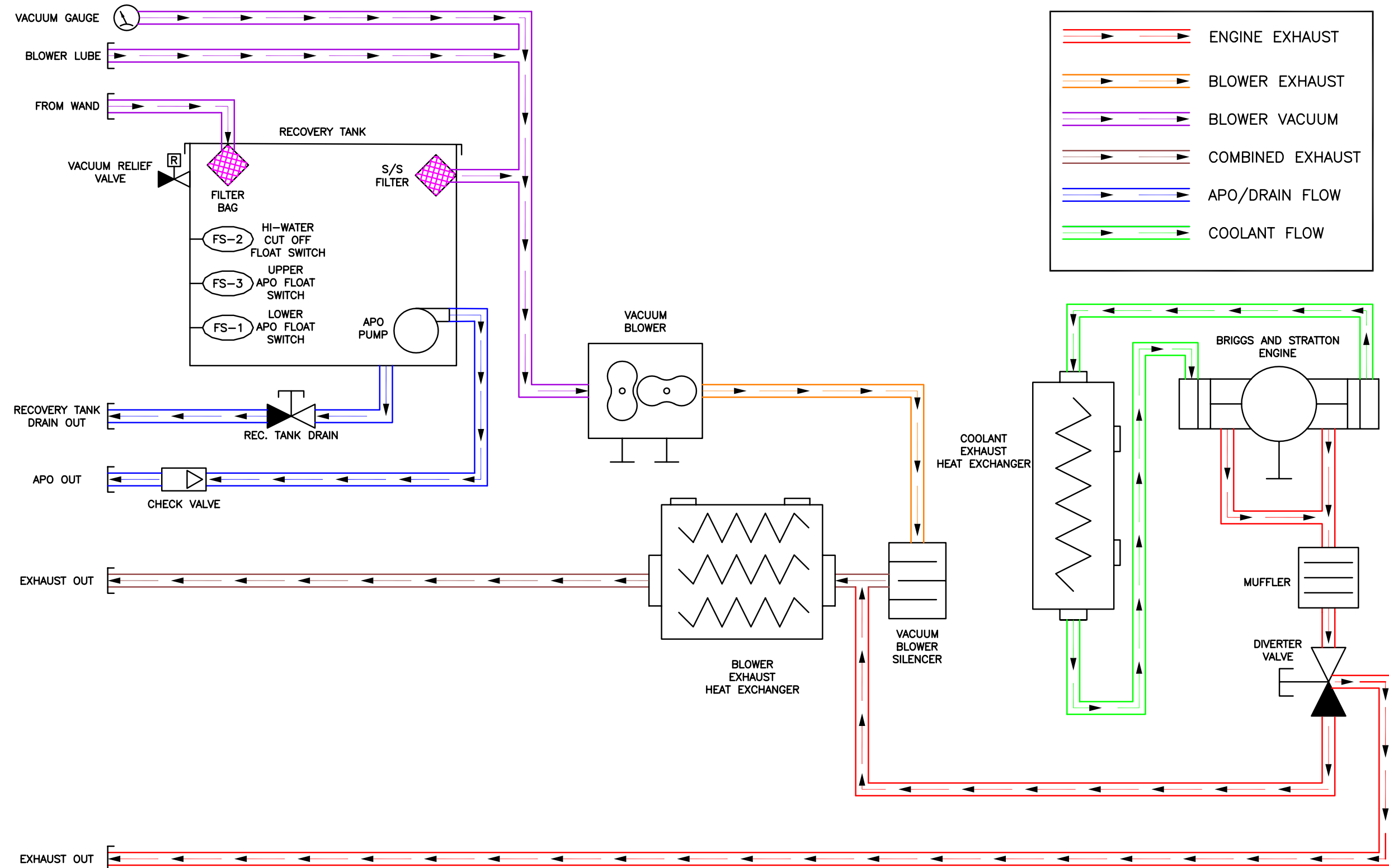

Figure 5.4 Exhaust, Vacuum, Coolant & APO Flow Diagram

D5736, Rev A



Heating System Troubleshooting

1.0. Machine overheats and shuts down

- 1.1. **Primary orifice or filter screen is restricted.** Remove and inspect. Clean as necessary.
 - 1.2. **Low pressure dump solenoid is restricted.** Inspect solenoid and the hose that delivers water to it. Clean or replace as necessary.
 - 1.3. **Diverter valve is stuck or out of adjustment.** Operate diverter valve manually (*make sure exhaust system is cool*) to determine if the movement of the valve is restricted. Repair or adjust as necessary.
 - 1.4. **Diverter valve and low pressure dump solenoid are not functioning.** Check the fuses that provides power to the diverter mode relay and to the temperature controller.
 - 1.4.1. If a fuse is blown, inspect electrical system for worn and shorted wires. Repair or replace as necessary.
 - 1.4.2. If fuse is good, inspect diverter relay and diverter switch. If either is faulty, replace.
 - 1.4.3. If switch and relay are good, refer to qualified service technician to test temperature controller and RTD sensor.
 - 1.5. **Engine RPM is too high.** Check RPM with accurate tachometer and adjust as necessary to 3000 RPM.
-

2.0. Unable to achieve normal cleaning solution temperature

- 2.1. **System is in Divert mode or temperature control knob is turned down.** Inspect divert switch and temperature control. Change or adjust.
 - 2.2. **Diverter valve is not closing completely.** Inspect diverter valve for proper operation. Adjust linkage as necessary.
 - 2.3. **Diverter and hot water dump systems will not switch into “Cleaning” mode.** Refer to qualified service technician to test system.
 - 2.4. **Engine RPM is too low.** Check RPM with accurate tachometer and adjust as necessary to 3000 RPM.
 - 2.5. **Cleaning solution flow is too great.** Measure flow at cleaning tool.
-

- 2.5.1. Cleaning tool jet is too large or worn out. Inspect jet. Replace if necessary.
 - 2.5.2. Cleaning solution pressure is too high. Adjust pressure to normal. Inspect pressure gauge for accurate reading.
 - 2.6. **Heat exchangers have hard water scale build up internally.** Descale system.
-

Chemical System Troubleshooting

1.0. System will not prime

- 1.1. **Check valves in chemical pump are faulty.** Remove valves and inspect. Clean or replace as necessary.
 - 1.2. **Chemical pump diaphragm is faulty.** Remove and inspect. Replace as necessary.
 - 1.3. **Check valve in high pressure pump (the one that the chemical pump attaches to) is faulty.** Remove valve and inspect. Clean or replace as necessary.
 - 1.4. **Filter on feed line in chemical jug is clogged.** Inspect and clean.
 - 1.5. **Feed line from chemical jug is loose, pinched or cut.** Inspect and repair.
 - 1.6. **Three-way prime valve is faulty.** Inspect valve for leaks between ports. Replace as necessary. *Note: if the chemical system has been run dry, it is frequently necessary to insert the prime hose from the chemical jug into the vacuum inlet for a "boost" to purge all of the air from the system. Machines produced after April, 2002 will have the prime hose connected directly to the vacuum system.*
-

2.0. Chemical flow is unstable or low

- 2.1. **Air in lines.** Check that all fittings and connections are tight and in good condition. Repair or replace as necessary.
 - 2.2. **Filter screen in chemical jug is partially clogged.** Inspect and clean.
 - 2.3. **Three-way chemical valve is faulty.** Inspect valve for leaks between ports. Replace as necessary.
-

- 2.4. **Chemical metering valve is faulty or partially obstructed.** Inspect valve and clean or replace as necessary.
 - 2.5. **High pressure check valve is faulty.** Remove and inspect. Clean or replace as necessary.
-

3.0. Solution jug fills with water

- 3.1. **Three-way chemical valve is defective.** Check valve for leaks between ports. Replace as necessary
 - 3.2. **Inlet check valve in chemical pump is faulty.** Remove and inspect valve. Clean or replace as necessary.
-

4.0. Chemical in water box

- 4.1. **Chemical pump diaphragm is faulty.** Remove and inspect. Replace as necessary.
- 4.2. **High-pressure check valve is faulty.** Remove and inspect. Clean or replace as necessary.

This page intentionally left blank

High Pressure Pump -Maintenance

Boxxer 427

Section 6-1

DAILY

Check the oil level and the condition of the oil. The oil level should be up to the center of the sight glass on the back of the pump.

Use a 30 weight, non-detergent oil.



If the oil becomes discolored and contaminated, one of the oil seals may be damaged. Refer to the Service Section.

Do not operate the pump if the crankcase has been contaminated with water.



Do not leave contaminated oil in the pump housing or leave the housing empty. Remove contaminated oil as soon as it is discovered and replace it with clean oil.

PERIODICALLY

Change the oil after the first 100 hours of operation, and every 400 operating hours thereafter. When changing, remove the drain plug on the oil drain center located on the frame so all oil and accumulated sediment will drain out.



Do not turn the drive shaft while the oil reservoir is empty.



Protect the pump from freezing.

Service

The next few pages explain how to disassemble and inspect all easily-serviceable parts of the pump.



Do not disassemble the hydraulic end unless you are a skilled mechanic. For assistance, contact HydraMaster (425-775-7275) or the distributor in your area.

Servicing the Valves (See Figure 6-1)

1. Remove the hex valve plugs;
top—discharge
bottom—inlet
2. Unthread the valve plug and examine the O-ring under the plug for cuts or distortion. Replace it if it is worn. Lubricate new O-rings before installing.
3. Grasp the valve retainer by the tab at the top with needle-nose pliers, then remove the O-ring at the bottom of the valve chamber.
4. Inspect all valve parts for pitting, gouges, or wear. If wear is excessive, replace valve assembly.
5. Reinstall valve assemblies:
 - a) Using a clean towel, clean the valve chamber.
 - b) Install the O-ring into the high pressure manifold.
 - c) Install the valve assemblies into the high pressure manifold (the metal side of the valve faces the manifold).
 - d) Replace the O-ring on the hex valve plug.
 - e) Torque the plug to 30 foot pounds.

Figure 6-1 **Servicing the Valves**

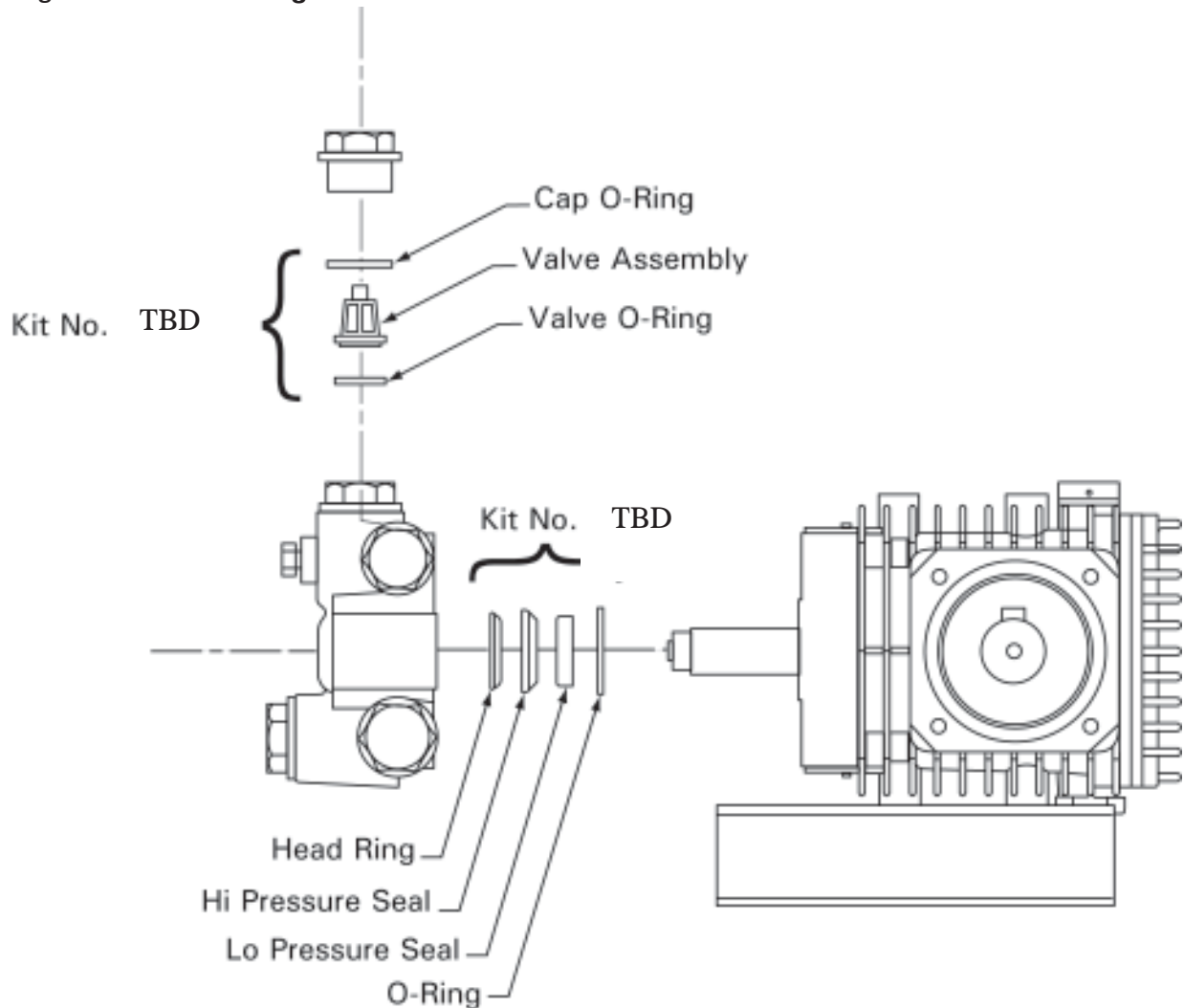

Removing the High Pressure Manifold

1. Using an M6 allen wrench, remove all eight of the socket head bolts.
2. Rotate the crankshaft by hand to start separation of the manifold head from the crankshaft.
3. Insert two flat-head screwdrivers on opposite sides to further separate the manifold from the crankshaft.

 **CAUTION**

To avoid damage to either plunger or seal, keep the manifold properly aligned with the ceramic plungers when removing it.

4. Remove the seal retainer from the manifold and inspect for wear.
5. Examine the ceramic plunger for cracks or scoring (refer to *Servicing the Plungers* for replacement).

Servicing the Low Pressure Seals and High Pressure Seals (See Figure 6-1)

1. Remove the low pressure seal from the seal retainer using a 90 degree pick tool.
2. Remove the high pressure seal from the manifold
3. Inspect the low pressure seal and high pressure seal for wear and replace if necessary.
4. Reinstall the low pressure seal into the seal retainers with the garter spring down.
5. Reinstall the high pressure seal:
 - a) Lubricate the seal chamber in the manifold.
 - b) Carefully square the high pressure seal into position by hand, with the grooved side down (metal back facing out).
 - c) Examine the seal retainer's O-ring and replace if worn. Lubricate the new O-ring before installing.
 - d) Press the seal retainers into the manifold until completely seated.

Servicing the Plungers

1. Using a hex tool, loosen the plunger retainer about three to four turns. Push the back to separate it from the retainer and finish unthreading the plunger retainer by hand.
2. Unthread the plunger retainer with sealing washer.
3. Remove the ceramic plunger, keyhole washer and barrier slinger from the plunger rod.

Reinstall the Ceramic Plungers:

1. Examine the sealing washer on the plunger retainer and replace it if it is cut or worn. Lubricate the new sealing washer for ease of installation and to avoid damage.
2. Apply Loctite 242™ to the threads of the plunger retainer and press it into the ceramic plunger. Thread 'hand'-tight, then torque the bolt to 4.4 foot pounds.
3. Install the seal retainer with holes to the top and bottom, and forward.

Reinstall High Pressure Manifold

1. Slip the seal retainer over the ceramic plungers with the holes to the top and bottom and forward.
2. Turn the shaft by hand to line up the plungers so that the end plungers are parallel.
3. Lightly lubricate the plungers and carefully slide the manifold head onto the plungers while supporting it from the underside to avoid damaging the plungers.
4. Reinstall the socket head bolts and torque to 4.4 foot pounds.

Servicing the Crankcase

1. While manifold, plungers, and seal retainers are removed, examine the crankcase seals for wear.
2. Rotate the crankshaft oil seal externally for drying, cracking or leaking.
3. Consult your HydraMaster distributor if crankcase servicing is necessary.

Figure 6-2 Pump Assembly
D-5574 Rev D

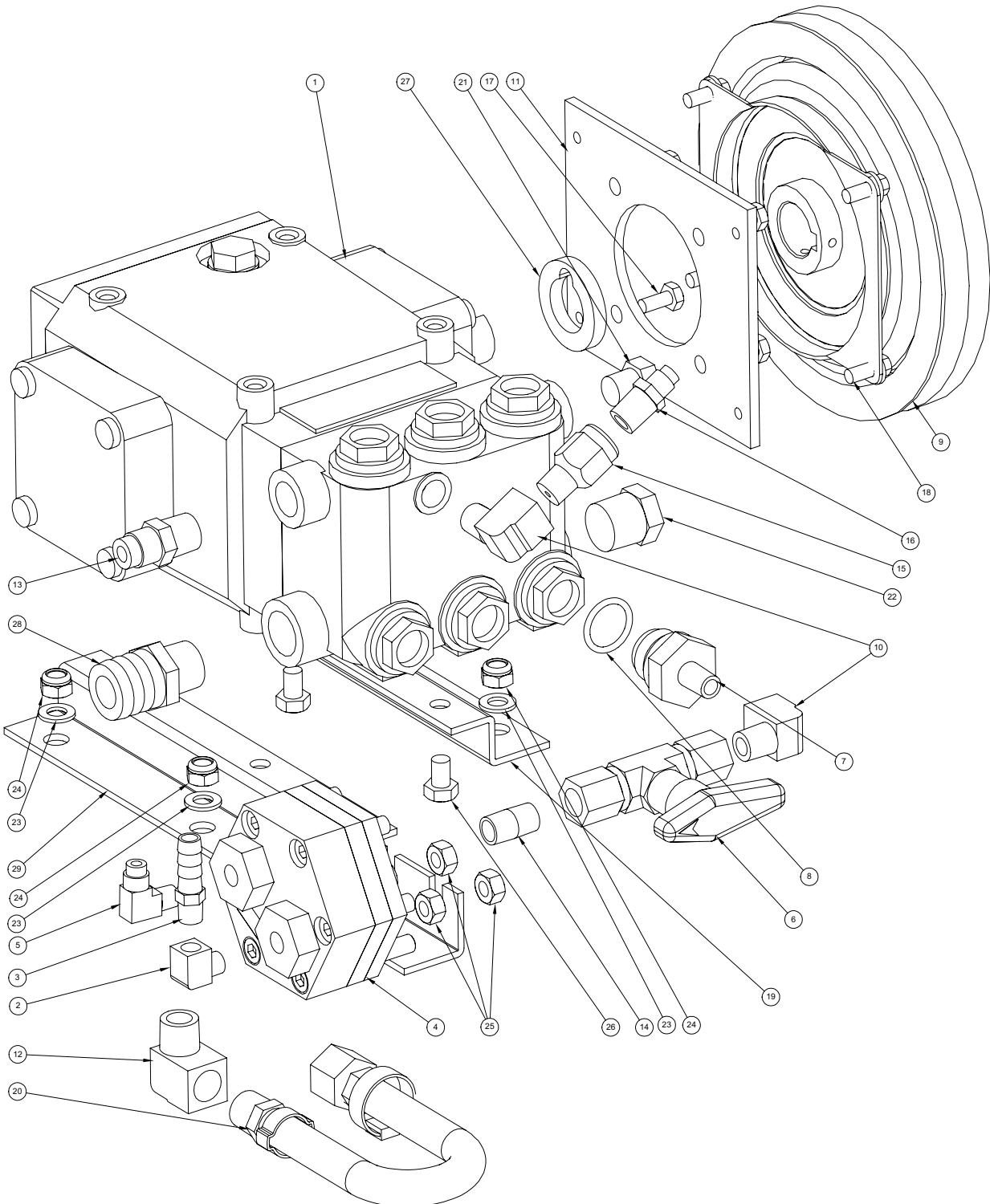

Pump Assembly Parts List

Item	Part Number	Description	Qty
1	000-111-041	Pump, Hydra Pump V - Boxxer 427	1
2	000-052-084	Elbow, 1/8" NPT Street	1
3	000-052-099	Insert, #26 (1/8" NPT x 3/8" Barb)	1
4	Fig. 1-18	Assembly, Chemical Pump - Boxxer 427	1
5	000-052-531	Elbow, 1/8" NPT x 1/4" SAE	1
6	000-169-176	Valve, 2 Way Chemical Pump	1
7	000-001-096	Adapter, Chemical Pump To Comet Pump	1
8	000-097-057	O-Ring, Adapter - Chemical Pump	1
9	000-036-008	Clutch, Electric Pump	1
10	000-052-085	Elbow, 1/4" NPT Street	2
11	000-105-312	Plate, Clutch Mount - Hydra Pump V - Boxxer 427	1
12	000-052-086	Elbow, 3/8" NPT Street	1
13	000-052-128	Nipple, 3/8" NPT x 3/8" Male Propane	1
14	000-052-517	Nipple, 1/4" NPT Close	1
15	000-135-052	Regulator, Hi PSI Snubber	1
16	000-052-527	Nipple, 1/4" SAE x 1/4" NPT	1
17	000-143-221	Screw, M6-1 x 14mm Lg. Hex Head	4
18	000-143-141	Screw, 1/4"-20UNC x 1/2" Lg. Whiz Lock	4
19	000-114-017	Rail, HydraPump V Mounting - Boxxer 427	1
20	000-068-219	Hose, Spitfire Pump Drain	1
21	000-106-003	Plug, 3/8" NPT Hex	1
22	000-106-004	Plug, 1/2" NPT Hex	1
23	000-174-049	Washer, 5/16" Flat	4
24	000-094-038	Nut, 5/16"-18UNC Nylock	4
25	000-094-013	Nut, 5/16"-24UNF Hex	4
26	- - -	Screw, 8mm x 1.0 x 12mm Lg.	4
27	000-154-145	Spacer, Comet Pump Clutch - Boxxer 427	1
28	000-052-753	Insert, #816 (1/2" NPT x 1" Barb)	1
29	000-114-019	Rail, HydraPump V / Chem Pump Mounting - Boxxer 427	1

High Pressure System Troubleshooting

1.0. Will not come up to normal cleaning pressure

- 1.1. **Pressure adjusting valve is defective or dirty.** Disassemble valve. Repair or replace if necessary.
- 1.2. **Worn seals or valves in pump.** Test pump output volume directly from pump at normal running RPM. If volume is below manufacturers specifications, replace seals and inspect for defective valves.
- 1.3. **Pump RPM is too low.** Check engine RPM and adjust as necessary to 3000 RPM. Check for loose pump belt. Adjust tension as necessary.
- 1.4. **High temperature dump solenoid is activated.** Refer to Heating System section IV.
- 1.5. **Primary system control orifice is missing or loose.** Remove filter and inspect. Tighten or replace as necessary.
- 1.6. **Primary system control orifice has been exchanged with secondary (hot water dump) orifice.** Inspect and reverse as necessary.
- 1.7. **Primary orifice is worn.** Measure orifice size and replace as necessary.

2.0. No pressure reading on PSI gauge

- 2.1. **Pump switch is not turned on.** Turn on switch
- 2.2. **No water in water box.** Refer to section 5.0.
- 2.3. **Pump belt is broken.** Replace belt.
- 2.4. **Pump clutch is not activated. There *is no* water in water box.** Check system back to source to locate cause of interruption to water flow.
- 2.5. **Pump clutch is not activated. There *is* water in the water box.** Check for 12 volts at clutch. If 12 volts is present, replace clutch.
 - 2.5.1. If 12 volts is not present, check fuse that supplies power to the low-water relay. If fuse is good and there is 12 volts at the relay, check the low water switch in water box.
 - 2.5.2. If low water switch has no continuity when float is up, replace the switch. If switch is good, replace the low water relay.

3.0. PSI gauge reads normal; low pressure from wand

- 3.1. **There is a restriction in the cleaning tool.** Inspect tool jet and clean or replace as necessary. Inspect any filters in the cleaning tool and clean or replace as necessary.
- 3.2. **There is a defective quick connect in the system.** Inspect each quick connect and replace as necessary.
- 3.3. **There is a restriction in one of the solution hoses.** Remove quick connects and inspect hoses. Clean or replace as necessary.
- 3.4. **There are hard water deposits restricting the system between the afterburner heat exchanger and the high-pressure solution connection at the front of the machine.** Descale the machine. If this doesn't solve the problem, disassemble this portion of the system until the restriction is located.

4.0. Pressure pulsation

- 4.1. **Water in the water-box is too hot and is approaching boiling point.** Check temperature of water in the water-box. If it is too high, refer to Heating System section IV.
- 4.2. **There is an air leak between the water box outlet and the pump inlet.** Physically check all hoses and fittings for cuts, breaks, cracks or tightness. Repair as necessary.
- 4.3. **One of the intake or outlet valves in the high pressure pump is defective or is being held open by debris.** Remove each valve and inspect for correct operation.

5.0. Water box empty or fills slowly

- 5.1. **There is a restriction in the water supply system.** Inspect the supply system from the source through the incoming quick connects.
- 5.2. **The float valve in the water box is defective.** If there is adequate water flow to the incoming valve in the water box, disassemble and inspect the valve. Repair or replace as necessary.

6.0. Water box overflows

- 6.1. **There is either debris caught in the valve or the valve seal is bad.** Disassemble valve and repair or replace as necessary.
- 6.2. **The float has absorbed water and has lost buoyancy.** Detach float and check to see if it will float to the surface. Replace as necessary.
- 6.3. **The float has come out of adjustment.** Readjust float as necessary.

This page intentionally left blank

Cleaning Wand Parts

Boxxer 427

Section 7-1

Figure 7-1 Valve Assembly
C3652

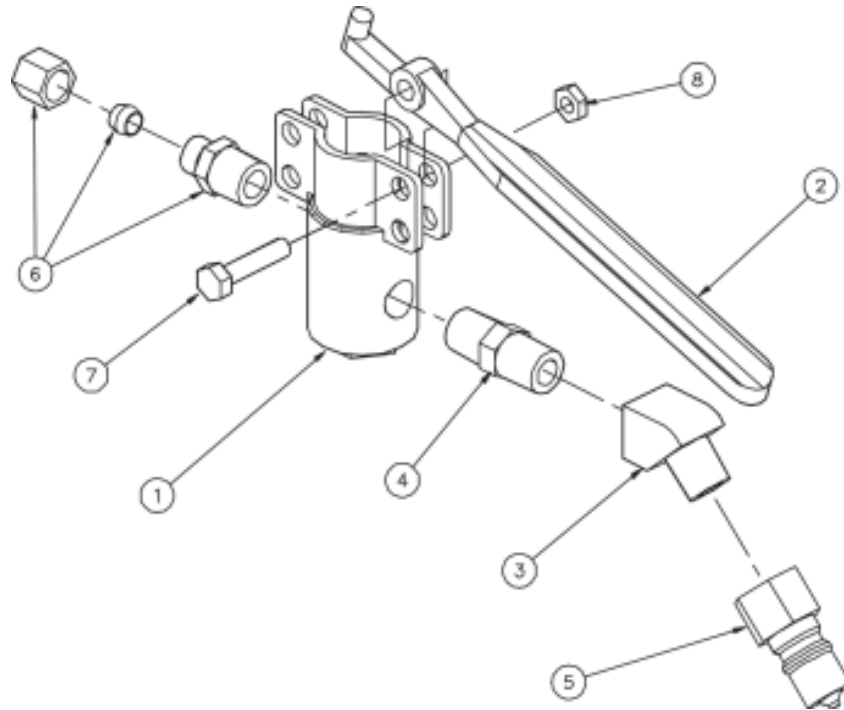

ITEM	PART NO.	DESCRIPTION	QTY
1	169-058	Valve, s/s HM Solution	1
2	167-013	Trigger, Hydra Hoe Valve - Brass	1
3	052-082	Elbow, 1/4" Brass 45 Street	1
4	052-095	Nipple, 1/4" s/s Hex	1
5	052-050	Quick Connect, 440 M with Viton	1
6	052-152	Compression, 1/4" Male Hydra Hoe Fitting	1
7	143-002	Screw, 1/4 - 20 x 1" HHC s/s	1
8	094-009	Nut, 1/4 - 20 s/s Nylock	1

Figure 1-2 Solution Valve Assembly
B1234

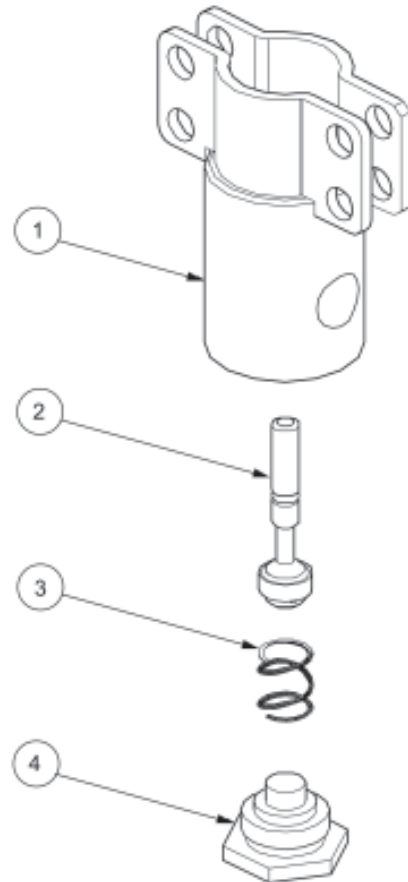

ITEM	PART NO.	DESCRIPTION	QTY
1	600-012-001	Valve Body Sub Assembly	1
2	600-012-002	Valve Stem Sub Assembly	1
3	155-003	Spring, HM Solution Valve	1
4	027-001	Cap, Brass	1

Figure 1-3 Valve Stem Assembly
B3743

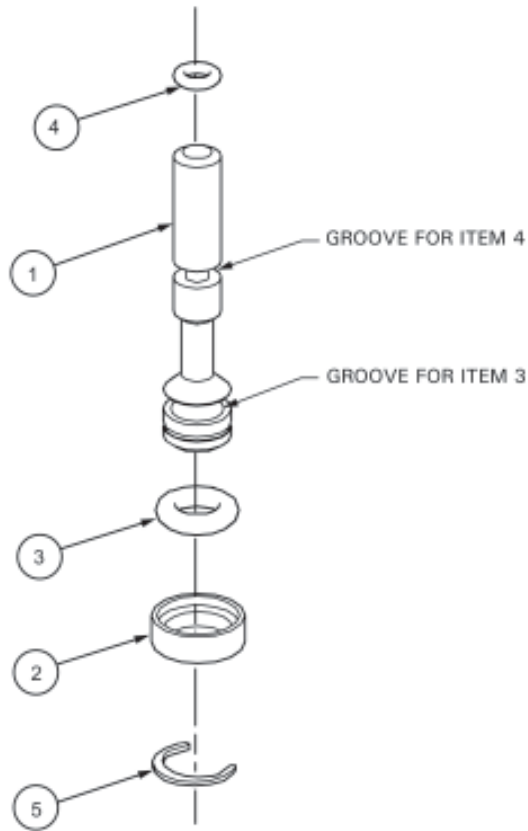

ITEM	PART NO.	DESCRIPTION	QTY
1	107-129	Plunger, HM Solution Valve	1
2	139-003	Ring Keeper, HM Solution Valve	1
3	097-010	O-Ring, HM Valve Plunger - Large	1
4	097-022	O-Ring, Solution Valve Flow Meter - Small	1
5	139-004	Ring, Solution Valve Stem Snap	1

Figure 1-4 Hydra Hoe Wand Assembly
C2660

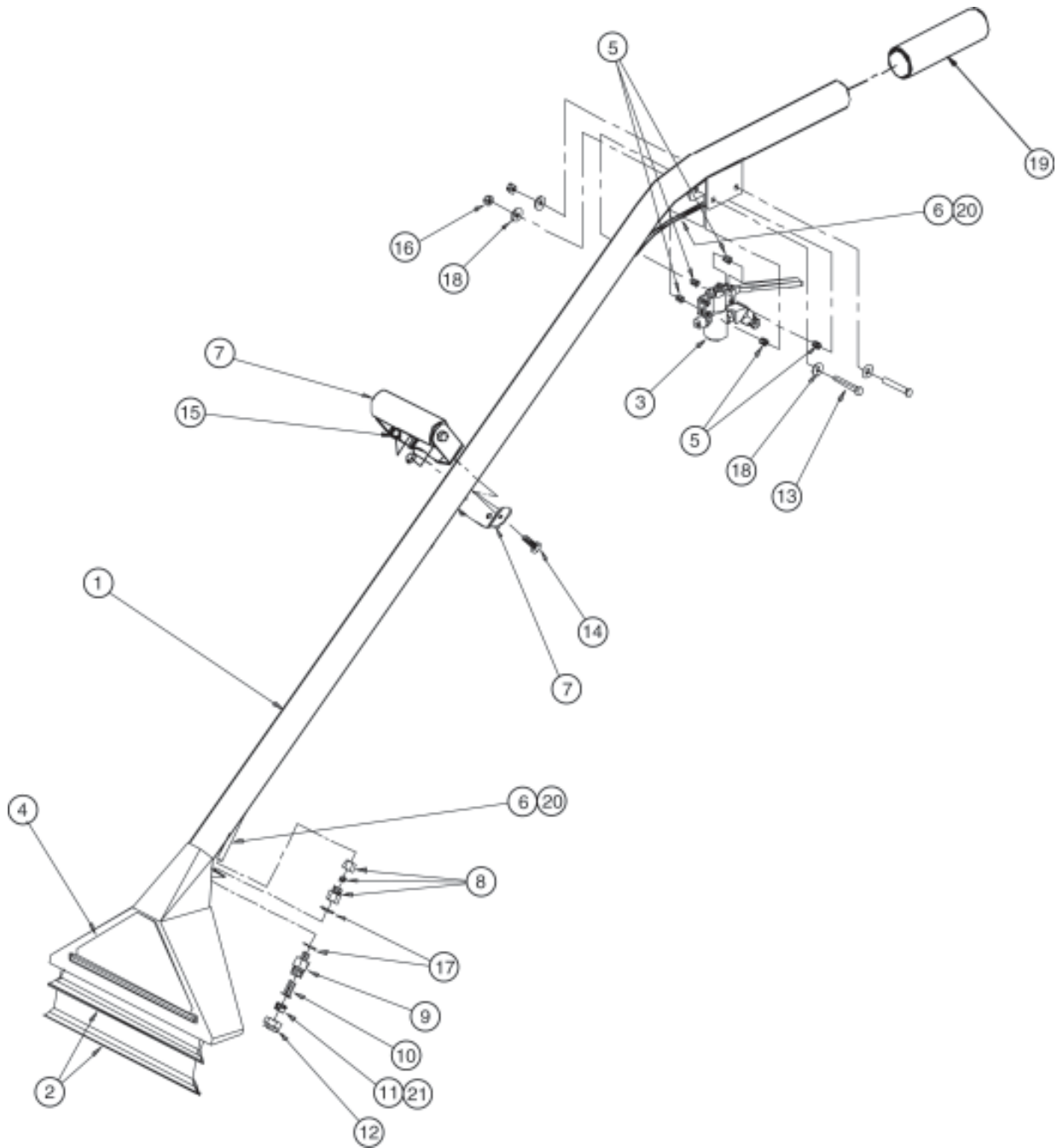

Hydra Hoe Wand Assembly Parts List

ITEM	PART NO.	DESCRIPTION	QTY
1	173-001	Wand Kit, 12" s/s Truckmount	1
2	082-004	Lips, 12" s/s HM Wand (2 Pieces)	1
3	169-055	Valve Assembly, s/s Hydra Hoe with Trigger	1
4	081-015	Label, "HydraMaster" Wand	1
5	154-001	Spacer, ¼ x 5/16 s/s Solution Valve	5
6	168-001	Tube, Hydra Hoe Solution - ¼" OD s/s	1
7	061-006	Handle, Pressure Guide	1
8	052-151	Compression, 1/8" Female Hydra Hoe Fitting	1
9	052-153	Housing, Brass Stabilizer Wand Nozzle Fitting	1
10	186-001	Stabilizer - Jet Assembly Group	1
11	076-005	Jet, #6 s/s Hydra Hoe	1
12	094-028	Nut, Brass Jet Assembly Group	1
13	143-005	Screw, ¼ - 20 x 1 ¾" HHC	2
14	143-012	Screw, 5/16 - 18 x ¾" HHC s/s	2
15	094-035	Nut, 5/16 - 18 s/s Nylock Half	2
16	094-009	Nut, ¼ - 20 s/s Nylock	2
17	174-032	Washer, 3/8" s/s Flat	2
18	174-003	Washer, ¼" s/s Flat	4
19	061-007	Handle Grip Hydra Hoe	1
20	063-003	Harness Wrap, High Temp. ¼" - Gray	4
21	076-045	Jet, 8004E s/s T	1

This page intentionally left blank

Vacuum System

Boxxer 427

Section 8-1

The vacuum pump in this machine is commonly referred to as a 'positive displacement lobe' type blower. The performance and life of this unit is greatly dependent on the care and proper maintenance it receives.

Because of the close tolerances between the lobes and housing of the vacuum blower, solid objects entering the inlet will damage the internal lobes, gears, bearings or drive system.

To prevent this, a stainless steel filter screen has been placed at the vacuum inlet inside the vacuum recovery tank. This stainless steel screen is 'finger' tight and **should be removed for cleaning weekly.**

 **CAUTION**

Caution should be used when machine is being run for test purposes and the vacuum inlet on top of the machine is open.

To protect the vacuum blower from overloading and damaging itself, there is a vacuum relief system installed on the vacuum tank. When the vacuum tank inlet is completely sealed off, a maximum of 12 HG will be attained.

At the end of each day, an oil based lubricant should be sprayed into the blower lubrication port before shutting down the machine. Lubricate the vacuum blower *daily* to prevent rust deposits and moisture that will decrease the life of the vacuum blower.

 **CAUTION**

Foam passing through the blower could lead to serious problems. It is important to keep the vacuum tank foam free.

Read the vacuum blower manual carefully for proper oil change and grease application. The maintenance log may differ slightly from the manual, but the truck-mounted carpet cleaning machine application is very demanding of the vacuum blower and therefore it should be maintained more regularly.

 **CAUTION**

The vacuum tank is protected from overflowing by a vacuum tank float kill switch. The switch is not activated by foam, only by liquid.

VACUUM TANK FILTER BAGS

HydraMaster filter bags are designed to trap lint, sand and dirt that would normally collect at the bottom of your vacuum tank. The use of these bags, if emptied at the end of each job, will eliminate the build-up of much of the debris in the tank. The drawstring top of these bags is designed to be slipped around the incoming dirty water inlet in the vacuum tank.

Vacuum System Troubleshooting

1.0. Weak vacuum at wand. Gauge reads normal (10" to 12" with hoses & wand attached)

- 1.1. **Clogged hoses or wand tube.** Disconnect hoses and check carefully for an obstruction.
 - 1.2. **Excessive length of hoses connected to machine.** Make sure machine is rated for the conditions under which it is being operated.
-

2.0. Vacuum gauge will not come up to 12" hg

- 2.1. **There is an air leak somewhere in the vacuum system.** Check vacuum relief valve for proper adjustment. Carefully check all vacuum hoses for a cut or break. Check recovery tank lid gasket. Make sure recovery tank drain valve is fully closed.
 - 2.2. **Vacuum blower is turning too slowly.** Check engine RPM. Adjust as necessary to 3000 RPM.
 - 2.3. **The vacuum gauge is defective.** Test gauge and replace as necessary.
-

3.0. Vacuum gauge reads too high with no hoses attached

- 3.1. **Filter in recovery tank is clogged.** Remove and clean or replace as necessary.
- 3.2. **Hose from vacuum blower to recovery tank is collapsed internally.** Inspect and replace as necessary.

4.0. Noisy vacuum blower

- 4.1. **Vacuum blower is low on oil.** Inspect oil level and replenish as necessary. Note: Running vacuum blower low on oil can cause severe mechanical damage. If this situation occurs, it should be inspected by a qualified service technician.
- 4.2. **Vacuum blower has internal damage.** Refer to qualified service technician.

5.0. Vacuum blower is locked and will not turn.

- 5.1. **The machine has been unused for a period on time and the blower was not properly lubricated when it was shut down, causing rust to build up on internal surfaces.** Spray penetrating oil into blower inlet and let sit for at least one hour. Then *very carefully* use pipe wrench on outer diameter of pulley on blower shaft and attempt to free up blower. *Do not use wrench directly on blower shaft.* If unable to free up blower in this manner, refer to qualified service technician.
- 5.2. **There is internal damage to the blower.** Refer to qualified service technician.
-

Miscellaneous Troubleshooting

1.0. Water from exhaust

- 1.1. **The recovery tank has been filled with foam or overfilled with water.** Remove recovery tank lid and inspect. If full, drain tank then inspect high-level shutoff switch for proper operation. Clean or replace switch as necessary.
- 1.1.1. If foam is observed in recovery tank, use defoamer on carpet being cleaned.
- 1.2. **Condensation.** This will be more pronounced in cool weather and humid climates. Observe how long this condition persists after starting machine. If it is only until the machine *warms up, it is normal.*
- 1.3. **A heat exchanger is leaking.** Change the diverter mode switch back and forth between Divert and Heat Exchange mode. Observe which condition causes water to be expelled from exhaust.
- 1.3.1. If water is expelled while switch is in Heat Exchange mode, the engine exhaust after burner heat exchanger is leaking internally. Remove and test. Replace as necessary.
- 1.3.2. If water is expelled while switch is in Divert mode, the blower exhaust heat exchanger is leaking. Remove and test. Replace as necessary.

Engine Troubleshooting

Boxxer 427

Section 9-1

1.0. Will not turn over

- 1.1. **There is a loose or corroded battery terminal.** Clean and tighten the battery terminal connections.
- 1.2. **The battery is dead.** Recharge or replace the battery. Test the charging system. Repair if necessary. *WARNING: Do not attempt to jump-start this machine from a running vehicle. The amperage output from an automobile will damage the charging system of the truckmount.*
- 1.3. **The 25 amp main power fuse in the electrical panel has blown.** Inspect the wiring thoroughly to locate shorted or damaged wires.
- 1.4. **The vacuum blower has seized.** Attempt to turn the engine by hand. If it will not turn, refer to Vacuum section II, 5.0.
- 1.5. **The ignition switch is defective.** Test to see if there is 12 volts to the switch. If there is, but there is not 12 volts going from the switch, replace the switch.
- 1.6. **There is a problem with the starter solenoid.** If there is 12 volts at the battery connection and at the key switch connection with the key in the start position but there is not 12 volts on the starter connection of the solenoid, replace the solenoid.
- 1.7. **The starter motor is defective.** Check to see if the engine can be turned over by hand. If it can and if there is 12 volts from the starter solenoid to the starter, replace the starter.
- 1.8. **There is a mechanical problem with the engine.** If the engine can be turned over by hand and the vacuum blower is not locked, refer the engine to a qualified service technician to determine the cause of the problem.

2.0. Turns over but will not start. There is no spark

(Note: To check for spark, use the following procedure. Remove a spark plug from the engine. Attach the lead wire back onto the plug. Ground the threaded part of the spark plug to an unpainted engine surface. While holding the plug and wire assembly by the insulated wire, crank the engine over by turning the ignition switch to the "start" position. You should observe a blue spark between the two electrodes of the spark plug.)

- 2.1. **Recovery tank is full.** Empty the tank.
- 2.2. **Recovery tank float is defective.** Disconnect float. If engine starts, replace the float.
- 2.3. **The oil pressure switch is preventing the engine from starting.** Check the engine oil level. If it is low, add oil to the proper level. If the engine still will not start, disconnect the oil pressure switch. If the engine starts with the oil pressure switch disconnected, replace the oil pressure switch.
 - 2.3.1 Note: It is important to use only Briggs oil filters. Even though an after-market filter may fit, the internal by-pass system may not be compatible with the Briggs engine resulting in low oil pressure.
- 2.4. **The high temperature switch has shut the engine down.** Observe the temperature gauge. If it is above the normal operating range (230° or above), allow the machine to cool down. If it will still not start, disconnect the high temp switch. If the machine then starts, replace the switch.
 - 2.4.1. If the machine starts after it has cooled down, refer to the Heating System section, 1.0.
- 2.5. **The spark plugs are faulty.** Remove and inspect. Replace as necessary.
- 2.6. **The engine ignition system is malfunctioning.** Refer to a qualified engine service technician for inspection.

3.0. Turns over but will not start. There *is* spark.

- 3.1. **Fuel is not reaching the carburetor inlet.** Check the fuel pump. If the pump is working, inspect the fuel lines between the fuel source and the carburetor. Repair or replace any faulty parts as necessary.
 - 3.1.1. If the pump *is not* working, check for 12 volts and a ground at the pump.
 - 3.1.2. If 12 volts *is not* present at the pump, check the wiring to the pump, including the fuse. Repair or replace as necessary. Note: If the fuse has blown, carefully inspect the wiring for a shorted or damaged wire. Repair immediately.
 - 3.1.3. If 12 volts *is* present at the pump and the ground is good, replace the pump.
- 3.2. **The carb solenoid is malfunctioning.** Test for 12 volts and proper ground at solenoid. If both test okay, replace the solenoid.
- 3.3. **The engine is flooded.** Wait for a few minutes and attempt to start with the choke open. Note: If the engine has been flooded, it may be necessary to remove and clean the spark plugs.
- 3.4. **The spark plugs are dirty or worn.** Inspect and replace as necessary.

3.5. **There is a mechanical problem with the engine.** Have engine inspected by a qualified engine service technician.

4.0. Starts then dies immediately

4.1. **The oil pressure switch is activated.** Check engine oil for proper level. If oil level is okay, disconnect switch. If the engine starts, replace the switch.

4.1.1. Note: It is important to use only Briggs oil filters. Even though an after-market filter may fit, the internal by-pass system may not be compatible with the Daihatsu engine resulting in low oil pressure.

5.0. Will not come up to normal operating RPM

5.1. **Throttle linkage is out of adjustment.** Inspect for broken or loose linkage. Repair or replace as necessary and adjust to proper RPM. Note: It is important to use an accurate tachometer to adjust engine speed to 3000 RPM while it is under a vacuum load of between 10"hg and 14"hg. Too high or too low will cause severe damage to machine components.

5.2. **There is excessive load on the engine due to the blower-to-recovery tank hose becoming delaminated.** Remove and inspect the inside of the hose. Replace as necessary.

5.3. **There is excessive back-pressure on the engine or blower exhaust.** Check for clogged blower heat exchanger.

6.0. Runs rough at medium or high speed

6.1. **One or both spark plugs are defective.** Remove and inspect spark plugs. Replace as necessary.

6.2. **A spark plug wire is loose at the spark plug or has been damaged.** Inspect wire. Replace wire and coil as necessary.

6.3. **Low compression on one or both cylinders.** Check compression. If low, check valve adjustment. If incorrect, adjust to proper specs. This operation should be performed by a qualified service technician.

6.3.1. If adjustment is okay, there is a possibility of burned valves, burned head gasket or worn cylinders. Refer to qualified engine service technician.

6.4. **Poor spark on one or both cylinders.** Refer to qualified engine service technician.

- 6.5. **Inadequate fuel supply to the carburetor.** Test the fuel volume at the carburetor by removing the fuel line from the carburetor inlet and placing the line in a metal container with a minimum of 16 oz capacity. Turn on the ignition switch to operate the fuel pump. The fuel flow volume should be 12 oz / minute. Check for clogged filter or obstructed fuel line. Also check to make sure the fuel pump is mounted vertically and is close to the fuel source. Repair as necessary.
-

7.0.Runs rich (Black smoke)

- 7.1. **Dirty air filter.** Inspect and replace as necessary.
- 7.2. **Choke is partially closed.** Inspect and adjust or repair as necessary.
- 7.3. **Excessive fuel to carburetor.** Insure that fuel pump is proper PSI rating. A fuel pump with a psi rating in excess of that of the pump supplied with the machine could overpower the inlet valve in the carburetor, causing excessive fuel to be supplied to the carburetor.
-

8.0.Engine overheats

- 8.1. **Poor ventilation in vehicle.** All cargo area doors must be open for proper ventilation. Roof vents are strongly recommended for machines that are operated in hot climates. Any item that might restrict air flow to the machine such as other equipment or a solid divider should be moved or modified to permit proper air flow.
- 8.2. **Low engine oil level.** Check oil level and replenish as necessary.
- 8.3. **Engine RPM too high.** Check RPM with an accurate tachometer. Adjust as necessary to 3000 RPM.
- 8.4. **Restricted engine or blower exhaust.** Disassemble exhaust components to locate restriction. Repair as necessary.

Electrical System

Boxxer 427

Section 10-1

The Boxxer electrical system, in keeping with the entire machine concept, has been kept to a minimum so as to keep any necessary troubleshooting as easy as possible.

The entire electrical system operates on 12 volts DC which is provided by a battery. Battery levels are sustained by a 16 amp alternator inside the engine.

NOTE: When a new battery is installed, check that it is properly charged before installation or damage to the charging regulator may occur.

This page intentionally left blank

Figure 10-1 Wiring Schematic

D-5738 Rev E

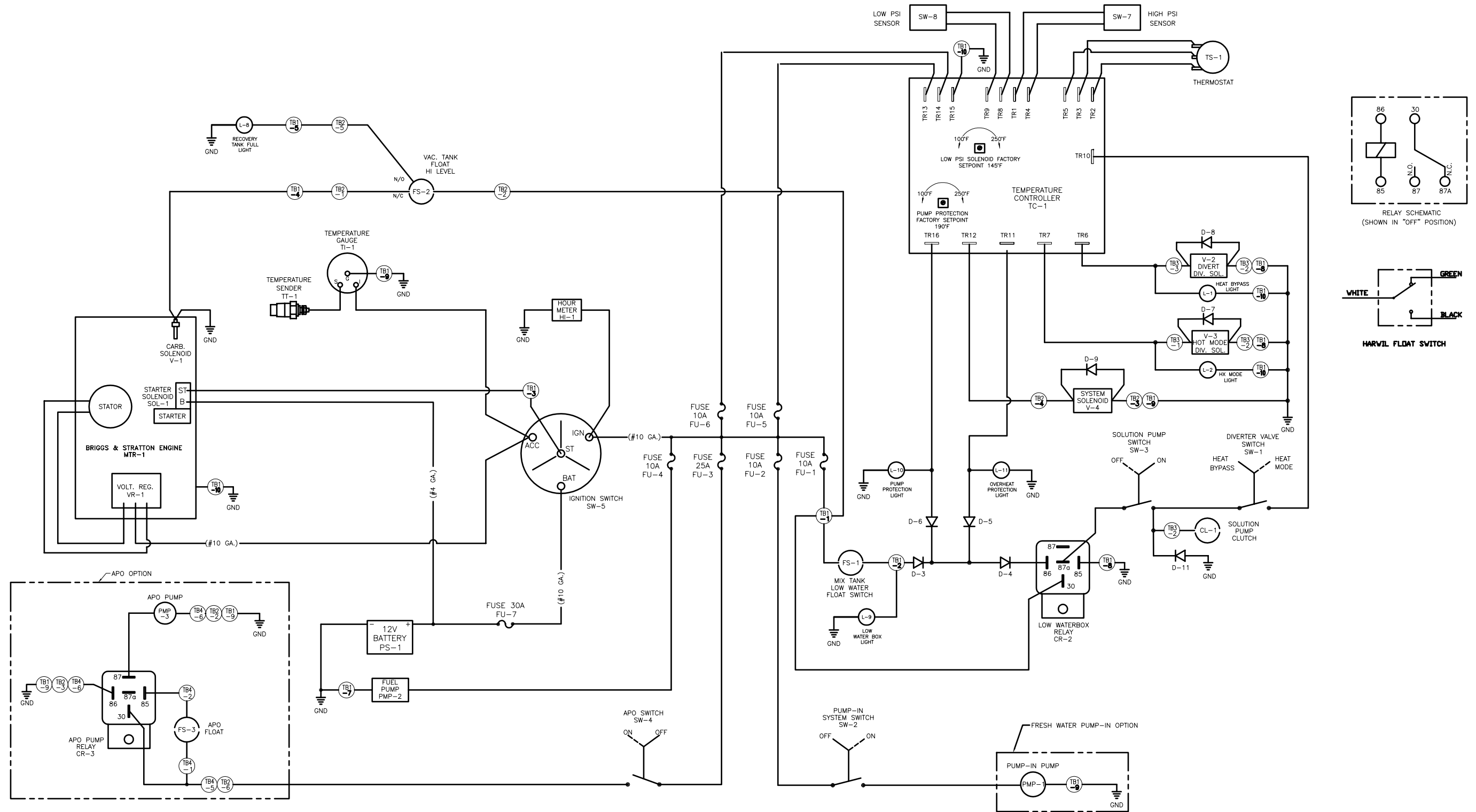

Figure 10-2 Wiring Diagram

D-5737 Sht 2, Rev H

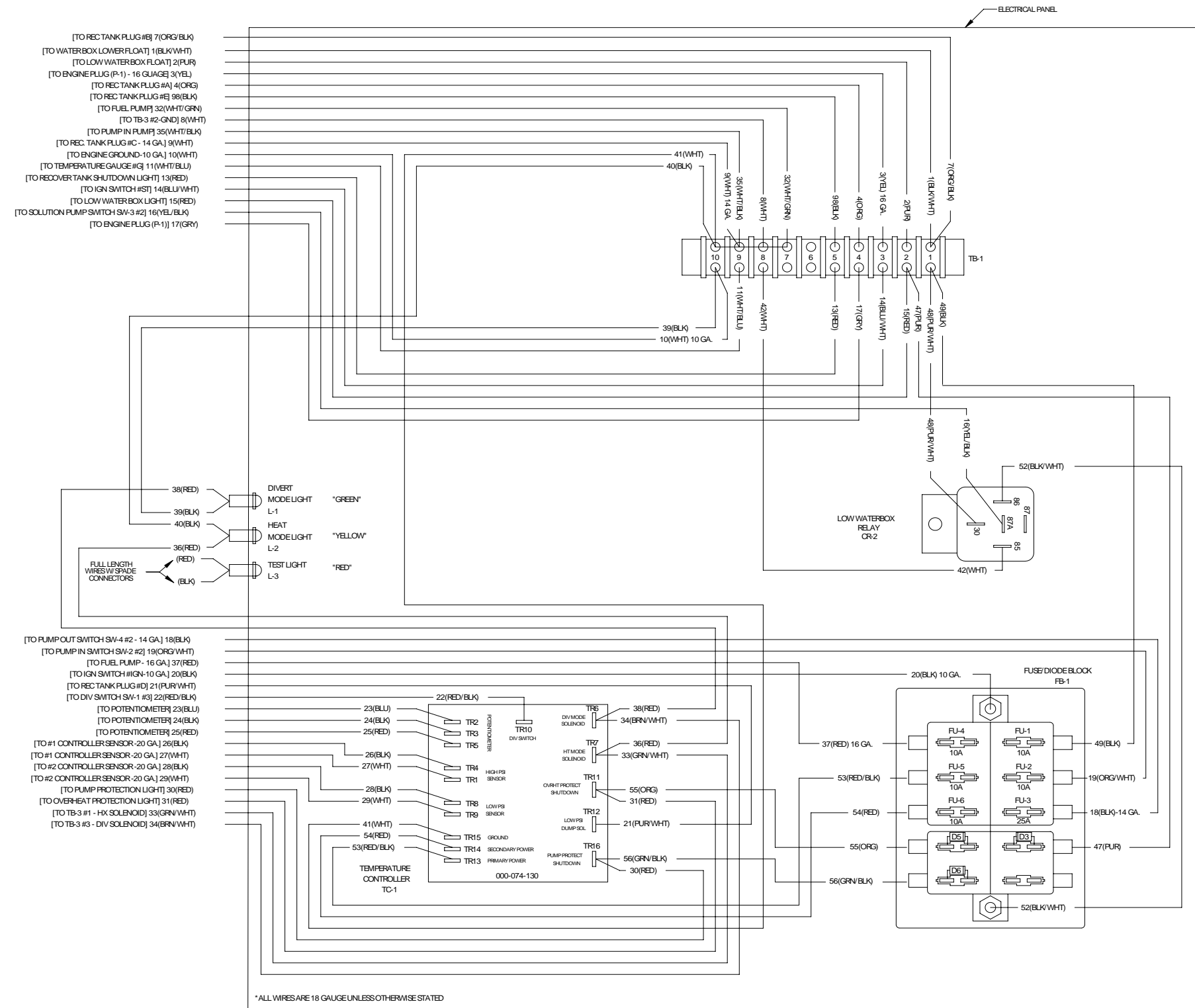

Figure 10-3 Wiring Diagram

D-5737 Sht 3, Rev H

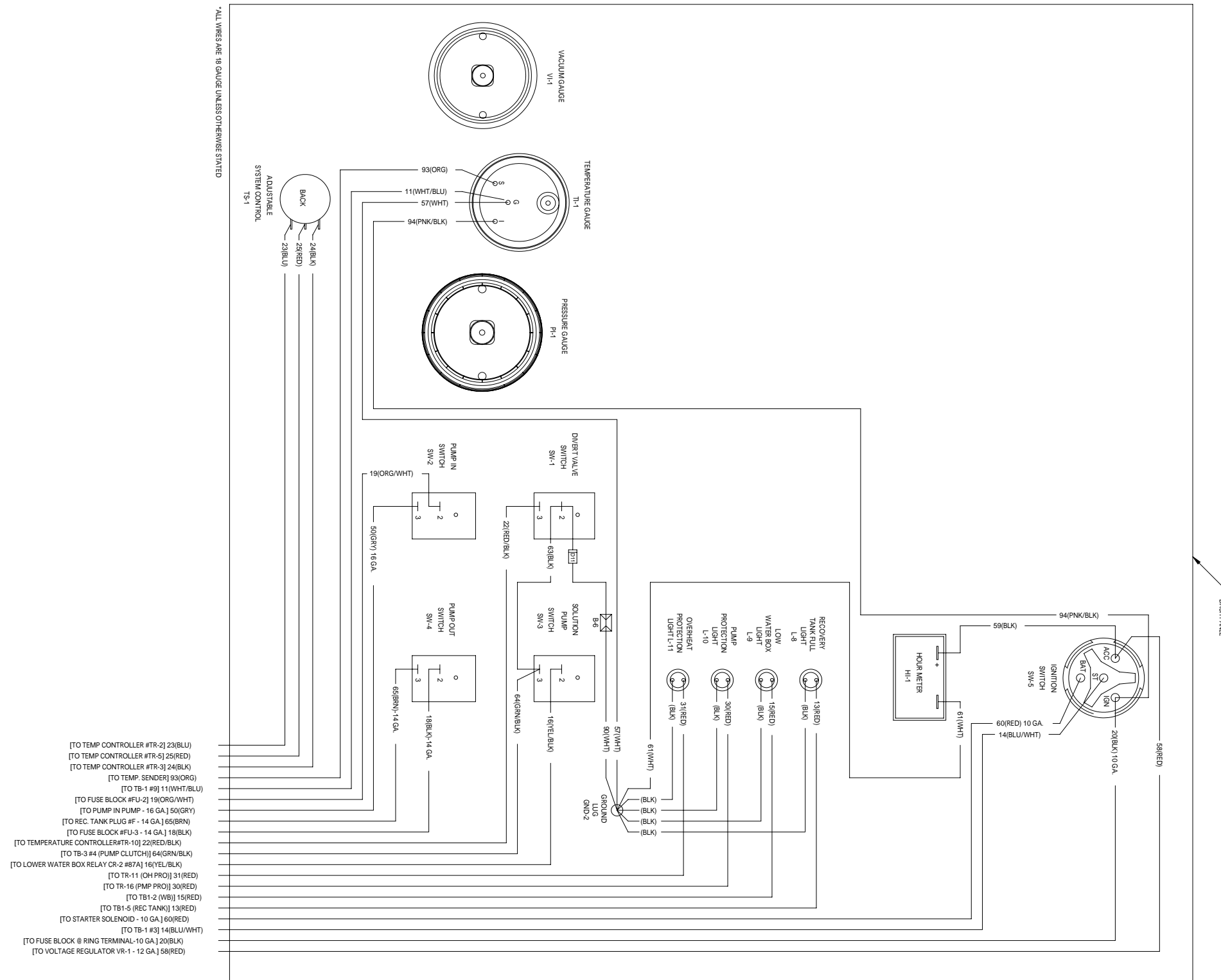
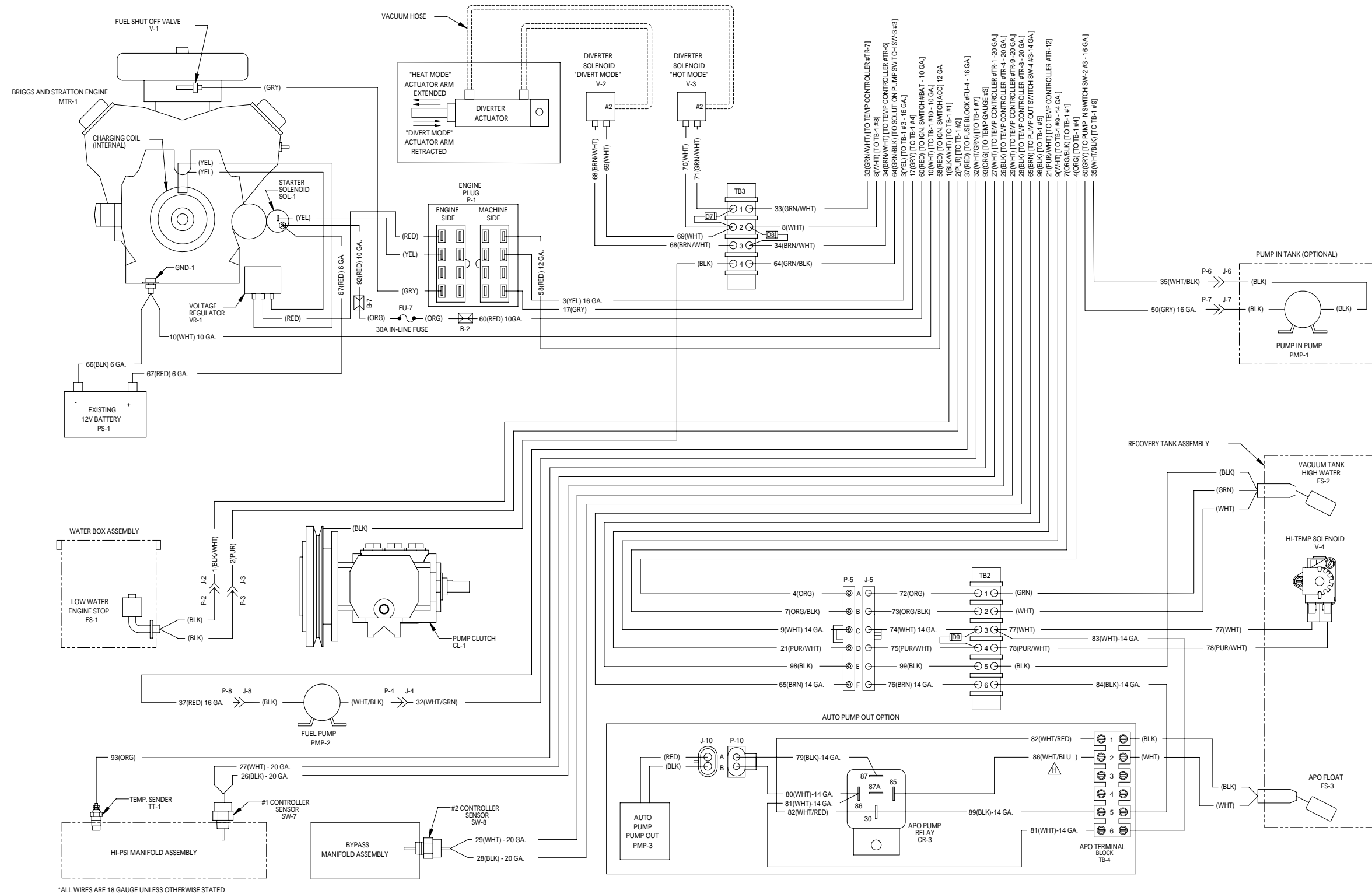

Figure 10-4 Wiring Diagram

D-5737 Sht 4, Rev H



*ALL WIRES ARE 18 GAUGE UNLESS OTHERWISE STATED

Electrical Troubleshooting

No.	Problem/Possible Cause	Solution
1.0	The engine is not charging the battery.	
1.1	The <i>regulator/rectifier</i> is bad.	Check the B+ voltage from the regulator/rectifier to ground. With the engine running at normal RPM the voltage should be 12.5 to 14.5 DC volts. If necessary, replace the regulator/rectifier.
1.2	The <i>stator winding</i> is bad.	Check for AC voltage at the regulator/rectifier. The stator should be producing an AC voltage of around 25 to 40 volts. Check your Owner's manual for the exact voltage. If necessary, replace the stator winding.

No.	Problem/Possible Cause	Solution
2.0	The fuse is blown.	
2.1	There is an <i>electrical short</i> in the system.	Check for a loose wire or a wire that has rubbed it's insulation off and is shorting out to ground. Unscrew each individual wire (except the white wires) one at a time until the fuse does not trip. Then trace that circuit.

This page intentionally left blank.

Machine Maintenance

Boxxer 427

Section 11-1

To avoid costly repairs and down-time, it is imperative to develop and practice good maintenance procedures from the beginning. These procedures fall into daily, weekly, monthly and quarterly increments, and are outlined below. All recommended maintenance must be performed by competent service personnel.

Important: Record the date and machine hours on the maintenance log.

We have provided a maintenance log for your convenience at the end of this section. Records of maintenance must be kept and copies may be required to be furnished to HydraMaster before the warranty is honored. It is recommended that you affix a copy of the log on the vehicle door near your unit for convenience and to serve as a maintenance reminder.

OPERATIONAL MAINTENANCE

DAILY:

- Check engine oil level.
- Check high pressure pump oil. Add as necessary.
- Inspect garden hose screen. Clean as needed.
- Visually inspect machine for loose wires, oil leaks, water leaks, etc.
- Lubricate blower with an oil based lubricant through blower inlet.

WEEKLY:

- Inspect vacuum tank s/s filter and filter bag for tears, holes, etc. Clean, repair or replace as needed.
- One time change of oil and oil filter after first 20 hours of use.
- Check oil level in blower.
- Check drive system screws. Tighten as needed.
- Check pump drive belt for wear.

WEEKLY (cont.):

- Check pump pulleys.
- Check high pressure water lines for wear or chafing.
- Check all nuts and bolts. Tighten as needed.
- Inspect vacuum relief valve. Clean and lubricate as necessary.
- Clean vacuum tank thoroughly with high pressure washer.
- Check wiring for chafing.
- Flush water and chemical system with 50/50 white vinegar solution.
- Change engine oil (every 50 hrs.).

MONTHLY:

- Change oil filter (every other oil change).
- Check engine air cleaner filter. Clean as necessary.
- Remove pressure bypass valve piston plate. Grease plate. Reinstall.
- Check water level in battery. Clean connections as needed.

QUARTERLY:

- Check fuel lines.
- Clean and gap spark plugs.
- Check drive coupler for cracks or wear. Replace as necessary.
- Change oil in blower.
- Change pump oil.
- Grease blower bearing fittings.

500 HOURS:

- Check coupler element between the engine and the blower, replace as necessary.

AS REQUIRED: DE-SCALING

Scale deposits on the interior of the heating system can cause a noticeable loss in heating performance. Deposits of this kind result from hard water deposits, excessive chemical use, improper chemicals, etc. The frequency with which de-scaling procedures are required will vary. If your area has particularly hard water or you see evidence of deposits in the water system, you may have to de-scale monthly.

To de-scale your system, add an appropriate de-scaler chemical to your mix tank. Circulate it through the heating system. Let it stand. Flush and repeat as necessary. Clean all screens and strainers, and check them frequently following de-scaling.

NOTE: If you are using T.M. DeScaler through the flow meter, make sure to run clean water through the flow meter after this procedure.

To de-scale using the recirculation kit (part no. 078-058), start with an empty mix tank. Fill a third of the mix tank with T.M. DeScaler. Follow the recommendations on the T.M. DeScaler label for proportions. Verify that the upper float is not lying horizontal, but floats below.

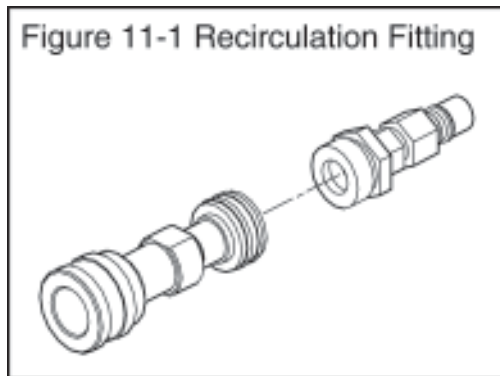

Attach the recirculation fitting provided in the kit to the garden hose quick connect (see illustration) and this combination to the front of the machine.

Attach one section of female/female solution hose to the outgoing solution fitting on the front of the machine and the other end to the garden hose and recirculation fitting combination that is attached to the front of the machine (or as many sections as you want, if you wish to de-scale your hoses).

Start the machine and allow it to run for three to five minutes. Do not leave the T.M. DeScaler solution in the system. Flush the system with clean water and turn the machine OFF.

OVERALL MACHINE MAINTENANCE

Maintaining the original appearance of your unit is important for two reasons:

1. It represents a big dollar investment for your cleaning business and its appearance should reflect that fact. A dirty machine is not professional.
2. Maintenance, troubleshooting, and repair is much easier to accomplish on a clean, well maintained unit. Regular cleaning of the machine offers you an opportunity to visually inspect all facets of the machine and spot potential problems before they occur.

The following maintenance is recommended by the manufacturer at the frequency indicated.

AFTER EACH JOB

- Check recovery tank, s/s filter and filter bag as required.

DAILY

- Wipe machine down thoroughly with a damp cloth.
- Flush recovery tank out thoroughly.
- Empty filter bag and inspect for rips, tears, etc. Replace as needed.
- Remove, thoroughly clean and reinstall stainless steel filter screen in recovery tank.
- Inspect and clean vacuum slot on cleaning wand.
- Check wand head for sharp edges that could tear carpet. File down as needed.
- Clean wand to maintain original appearance.
- Wipe down vacuum and high pressure hoses as needed.
- Visually inspect hoses for cuts, etc.

WEEKLY

- Wipe down entire unit as needed.
- Apply good coat of auto wax to all painted surfaces inside and out, and to control panel.
- Thoroughly clean recovery tank using high pressure hot water (unit with optional high pressure cleaning gun may be used for this).
- Remove stainless steel filter in recovery tank and thoroughly clean, removing all lint build-up. Inspect for damage and reinstall.
- Remove filter bag. Thoroughly clean and reinstall. If the bag is torn, replace it.
- Empty chemical from chemical container. Wash out thoroughly to remove any chemical build-up.
- Inspect chemical feed line strainer and use 50% white vinegar/water solution to remove any chemical build-up.
- Thoroughly clean wand and inspect for clogged jet, debris in vacuum slot and leaking fittings at valve.
- Apply light coat of auto wax to wand.
- Thoroughly clean vacuum and high pressure hoses including hose cuffs.
- Inspect for wear or damage to hoses and quick connect fittings.
- Inspect garden hose connect/adapter screen for debris. Remove and clean thoroughly.
- Inspect all lines for wear or abrasions that may cause possible leaks.

This page intentionally left blank

How to Order Parts

Boxxer 427

Section 12-1

To obtain a proper diagnosis of your malfunction, and to order warranty replacement parts or repairs, it is important that you proceed in the following manner:

WARRANTY PARTS ORDERS

1. Call the local distributor where you purchased your equipment and ask for the Service Department.
2. Have the following information ready:
 - A. Equipment Model
 - B. Date of Purchase
 - C. Hours on the Unit
 - D. Unit Serial Number
 - E. Description of Malfunction
3. Once it has been determined which parts are needed to correct the problem with your machine, make arrangements with your distributor to either perform the repairs or ship the parts to you.

PARTS ORDERS

Call your local distributor. In most instances, they either stock or have access to parts through a regional service center.

EMERGENCIES

If, for any reason, your distributor is unable to supply you with the necessary parts, they may call us and arrange for expedited shipping.

HydraMaster sells parts only through authorized distributors and service centers.

ONE FINAL NOTE

Any questions you have regarding the warranty program should be directed to the:

HydraMaster Customer Service Department
(425) 775-7275,
8 a.m. to 5 p.m.
Monday through Friday (PST).

We shall always endeavor to be fair in our evaluation of your warranty claim, and shall provide you with a complete analysis of our findings.

HydraMaster warranty covers only defective materials and/or workmanship for the periods listed. **Labor and/or diagnostic reimbursement is specifically excluded.**

Warranty Information

Boxxer 427

Section 13-1

To avoid misunderstandings which might occur between machine owners and manufacturer, we are listing causes of component failure that specifically voids warranty coverage. Such causes as listed below shall constitute **abuse** or **neglect**.

BLOWER:

- Failure to lubricate impellers daily with an oil based lubricant.
- Failure to lubricate bearings as recommended in blower manual.
- Failure to maintain proper oil levels in the blower.
- Failure to use the correct oil grade and viscosity as recommended in blower manual.
- Failure to properly maintain blower safeguard systems such as waste tank filter screen, vacuum safety relief valve and waste tank automatic shut-off system.
- Allowing foam to pass through blower.

HIGH PRESSURE WATER PUMP:

- Failure to maintain proper oil level as recommended in pump manual.
- Failure to change oil in pump at recommended intervals.
- Failure to protect pump against freezing.
- Failure to maintain pump protection shut-off system.
- Failure to use water softener in hard water areas.
- Use of improper chemicals.

VACUUM TANK:

- Failure to properly maintain filtering devices in tank.
- Failure to clean tank as recommended by manufacturer.
- Failure to maintain vacuum safety release in tank.
- Use of improper chemicals.

CHEMICAL SYSTEM:

- Use of improper chemical.
- Failure to use water softener in hard water area.
- Operating machine without proper chemical filter screen.
- Failure to protect against freezing.

CONTROL PANEL:

- Failure to protect flowmeter and water pressure gauge against freezing.

VACUUM AND SOLUTION HOSES:

- Failure to protect hoses against freezing.
- Failure to protect hoses against burns from engine and blower exhaust.
- Damage to hoses from being run over by vehicles.
- Kinking or cracking from failure to store or unroll hoses correctly.
- Normal wear and tear from everyday use.

CLEANING WAND:

- Failure to protect against freezing.
- Obvious physical abuse of wand.

WATER HEATING SYSTEM:

- Over-pressurization of the system (recommended maximum working pressure-1,000 PSI).
- Failure to protect against freezing.

HARD WATER DEPOSITS:

- Failure to use or maintain a water softening system or a properly installed magnetic-type de-scaler, whichever might be necessary, with machines operating in designated "Hard Water Areas" (3.5 grains or more per gallon).

WARRANTY PROCEDURE

Warranty coverage is available to you through *your local Distributor*.

If you have moved to a new area or have purchased a used machine and need information regarding your local distributor, call HydraMaster at (425) 775-7272 or email us at custsvc@hydramaster.com.

When calling your distributor, be sure to have the machine's information; model and serial number, ready for the service representative.

IMPORTANT: HydraMaster's warranty policy provides replacement parts without charge for thirty (30) days to distributors maintaining current account status. An invoice will be sent to the distributor for the amount of the parts sent. The customer's faulty parts **must be** returned for evaluation prior to the expiration of the thirty (30) day period. Upon warranty approval, a credit will be issued the distributor for the replacement parts invoice. **Warranty disapproval or failure to return the faulty parts within the thirty (30) day period allowed will result in the customer being charged for the replacement parts sent.**

FOR YOUR REFERENCE:

Model No. _____
Serial No. _____
Date of Purchase: _____
Purchased From (Distributor): _____

This page intentionally left blank

Accessories

Boxxer 427

Section 14-1

Genuine HydraMaster Accessories & Detergents

This section of your Owners Manual is devoted to Accessories and Detergents which we have found to be helpful and useful. These products can enhance your cleaning and reduce your labor costs!

HydraMaster Machine accessories are the most innovative collection available in the cleaning industry. Our patented **RX-20 Rotary Extractors** have changed the shape of steam cleaning. Our hoses and tanks are of the finest quality construction.

SafeClean Detergents have been specially prepared, not only to give you exceptional cleaning, but also to optimize your truckmount's operation and reliability. Most detergents don't work well under the high heat, high pressure conditions of truckmount use. SafeClean will maintain your machines's water pump and water heating systems at peak efficiency and help ensure fewer breakdowns.

For more information, or to order

Genuine HydraMaster Accessories and Detergents

Call your nearest authorized HydraMaster Distributor.

Product Updates

Boxxer 427
Section 15-1

